

LANCER | SOFT DRINK SYSTEMS

S4H Hi-Carb Superchiller

230V / 50Hz

Installation, Operation & Service Manual



Table of contents

1. Specifications and Features	3
1.1. Model	3
1.2. Specifications	3
1.3. Product features	3
2. Superchiller Safety Information	3
2.1 Safety Instructions.....	3
2.2 Recognise Safety Alert Symbols.....	4
2.3 Operating	4
2.4 Service & Maintenance.....	4
2.5 Flammable Refrigerants (R290).....	5
2.6 Carbon Dioxide (CO2)	5
3. Installation.....	5
3.1 Receiving	5
3.2 Unpacking.....	5
3.3 Selecting a Location.....	6
3.4 Connecting Python.....	7
3.5 Connecting to water supply	8
3.6 Plumbing the drain and CO2 exhaust	8
3.7 Connecting to CO2 Supply	8
3.8 Filling unit with water.....	9
3.9 Electrical Connection	9
3.10 Commissioning.....	9
3.11 Purge System	9
3.12 LED Display Panel	10
4. Scheduled Maintenance	11
4.1 Daily	11
4.2 Quarterly	11
4.3 Half Yearly	11
4.4 Yearly	11
4.5 Sanitisation of Beverage System	12
5. Diagrams & Parts	13
5.1 Postmix Assembly Diagram	13
5.2 Postmix Parts List	14
5.3 Refrigeration Assembly Diagram	15
5.4 Refrigeration Parts List	15
5.5 Electrical Assembly Diagram	16
5.6 Electrical Parts List.....	16
5.7 Body Panel Assembly Diagram	17
5.8 Body Panel Parts List.....	17
5.9 Plumbing Diagram	18
5.10 Wiring Diagram.....	20
6. Trouble Shooting	20
7. Carbonator and Icebank Probe Tests.....	22
7.1 Icebank Probe Check	23
8. Certificate of Warranty.....	24
9. Manufacturer's Checklist	25

1. Specifications and Features

1.1. Models

10004602 S4H22LA GENBEV – Superchiller with carbonation and soda recirculation pumps.
 10004603 S4H23LA GENBEV – Superchiller with carbonation, soda and water recirculation pumps.

1.2. Specifications

Voltage	230 Volts
Frequency	50 Hz
Max Current Draw	6.8 Amps
Ambient Temperature	2 - 40°C
Refrigeration Capacity	1440 Watts @ -10C SST
Heat Rejection	2200 watts max
Dimensions	
Width	910 mm
Depth	513 mm
Height	665 mm (775 with castors)
Weight	
Shipping	103 kg
Empty	96 kg
Operating	168 kg
Refrigerant	145g R290
Ice bank Weight	28 kg
Water Bank Capacity	72 litres
Construction	Stainless Steel
Drink Capacity	275 @ 40C/32C/40C Ambient/Water/Syrup 4 x 12-oz (355ml) drinks/minute @ 3 oz/second flowrate

1.3. Product features

Environmentally Friendly R290 Refrigerant
 Energy Optimised R290 Compressor
 Variable Speed EC Fan Motor
 Continuous Low Speed Fan Operation

2. Superchiller Safety Information



2.1 Safety Instructions

For your personal safety, and that of others working around you please read, understand, and follow thoroughly all safety instructions included in this manual and on the Superchiller.



- Review all applicable WHS (Work Health & Safety) regulations.
- Review all applicable Beverage Dispensing Gas Standards
- Learn how to operate the Superchiller and use the controls properly.
- Do not allow untrained personnel to operate the machine.
- Ensure that the Superchiller is maintained according to service manual instructions.
- Do not allow any unauthorised modifications to the machine.

2.2 Recognise Safety Alert Symbols





The safety alert symbol precedes Warning and Caution notes throughout this manual. To prevent personal injury or damage to the machine these alerts must be strictly adhered too.

	Warning	Alerts to a potentially hazardous situation that if not avoided CAN result in death, serious injury.
	Caution	Alerts to a potentially hazardous situation that if not avoided MAY result in injury or equipment damage.
	Warning	Risk of fire.

2.3 Operating





	Warning	Superchillers are intended for indoor operation only; do not operate outside unless suitably protected by a weatherproof enclosure. This appliance is not suitable for installation in an area where a water jet could be used.
	Caution	This appliance is not intended for use by persons (including children) with reduced physical, sensory or mental capabilities, or lack of experience and knowledge, unless they have been given supervision or instruction concerning use of the appliance by a person responsible for their safety. Children should be supervised to ensure that they do not play with the appliance.
	Caution	This appliance is intended to be used in commercial applications such as restaurants or similar.

2.4 Service & Maintenance

	Caution	Installation of Superchiller and service work should only be performed by fully trained & certified Electrical, Plumbing, & Refrigeration Technicians. In Queensland a gas work licence (hydrocarbon refrigerant) is required to undertake gas work on the gas system of a gas device in Queensland that uses fuel gas as a refrigerant such as charging, discharging or breaking into a refrigeration system.
	Warning	Carbonator contains CO ₂ gas and water under pressure. De-pressurise before performing any work on the system.
	Warning	ALL WIRING AND PLUMBING MUST CONFORM TO LOCAL AND NATIONAL CODES.
	Warning	SUPERCHILLER <u>MUST</u> BE ISOLATED FROM ELECTRICAL SUPPLY BEFORE COMMENCING ANY SERVICE OR MAINTENANCE WORK.

2.5 Flammable Refrigerants (R290)

This is a compression type appliance with R290 (Propane) refrigerant which is CFC-Free, environmentally friendly, but it is flammable.

	Warning	Keep ventilation openings, in the enclosure, or built-in structure, clear of obstruction.
	Warning	Do not use mechanical devices or other means to accelerate the defrosting process, other than those recommended by the manufacturer
	Warning	Do not damage the refrigeration circuit. In Queensland a gas work licence (hydrocarbon refrigerant) is required to undertake gas work on the gas system of a gas device in Queensland that uses fuel gas as a refrigerant such as charging, discharging or breaking into a refrigeration system.
	Warning	Use only genuine Hoshizaki Lancer replacement components or parts certified by Hoshizaki Lancer.

2.6 Carbon Dioxide (CO₂)

	Warning	The Superchiller uses a CO ₂ (Carbon Dioxide) supply. CO ₂ is a heavier than air, colourless, non-combustible gas with a faintly pungent odour. Personnel exposed to high concentrations of CO ₂ gas will experience tremors, which are followed rapidly by loss of consciousness and suffocation. If a CO ₂ gas leak is suspected, immediately ventilate the contaminated area before attempting to repair the leak.
---	----------------	--

3. Installation

	Warning	To avoid personal injury or damage, do not attempt to lift a Superchiller without help. Use of a mechanical lift is recommended. (NOTE: Empty S4H Superchiller weight: 96 kg)
---	----------------	---

3.1 Receiving

Each unit is completely tested under operating conditions and thoroughly inspected before shipment. At time of shipment, the carrier accepts the unit and any claim for damage(s) must be made with the carrier. Upon receiving units from the delivering carrier, carefully inspect shipping crate for visible indication(s) of damage. If damage exists, have carrier note damage on bill of lading and file a claim with the carrier.

3.2 Unpacking

	Caution	The use of gloves is recommended to protect hands from potential injury from sharp edges. The Superchiller must always be handled in the horizontal position.
---	----------------	--

Carefully unpack the Lancer S4H Superchiller from the shipping carton, remove the wooden base. Inspect unit for concealed damage and if evident, notify delivering carrier and file a claim against the carrier.

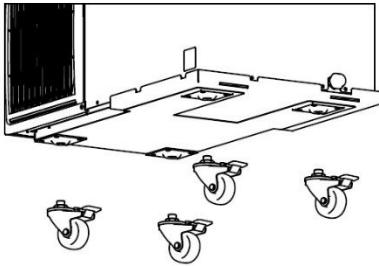

To install the castors, lift the chiller with appropriate help and screw the castors into the mounting plates provided. DO NOT tilt the chiller more than 45 degrees or lay chiller on its side.

3.3 Selecting a Location

	Warning	<p>Superchillers are intended for indoor operation only; do not operate outside unless suitably protected by a weatherproof enclosure. This appliance is not suitable for installation in an area where a water jet could be used. Superchillers are not to be installed in a kitchen.</p>
--	----------------	--

	Warning	<p>When positioning the appliance, ensure the supply cord is not trapped or damaged. Do not locate multiple portable socket-outlets or portable power supplies at the rear of the appliance.</p>
--	----------------	--

	Caution	<p>The Superchiller is not suitable for use in subfreezing temperatures. To prevent damage to the water supply line, turn off and drain unit when air temperature is below zero degrees Celsius.</p>
--	----------------	--

	Caution	<p>The Superchiller is only to be installed in locations where its use and maintenance is restricted to trained personnel.</p>
--	----------------	--

- The S4H Superchiller should be located in a well-ventilated, firm, level location close to water and electrical supplies, within 30m of the dispenser and with easy access for servicing.
- Ensure sufficient clearance around Superchiller to allow good fresh air circulation through the condenser – allow at least 200mm at rear and sides.

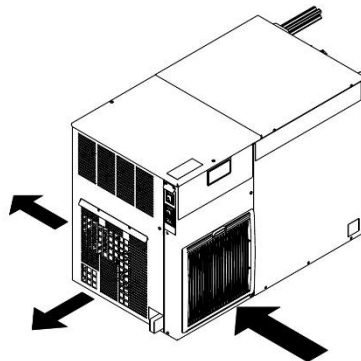

Ensure sufficient clearance for air flow. Do not block or obstruct airflow into the machine.

- Installation should only be performed by a qualified and competent technician.

	Caution	<p>Superchiller operational weight is 168kg; ensure that all supporting structures are certified for this loading by a registered Mechanical Engineer. Supporting structure must be securely fixed to floors or walls.</p>
--	----------------	--

3.4 Connecting Python

Connect Python to Chiller and Dispenser.

	<p>Caution</p>	<p>NOTE: The S4H Superchiller is rated to operate with a maximum of 30m of python connected.</p> <p>Exceeding manufacturer's ratings may cause damage to the Superchiller and void warranty.</p>
---	-----------------------	--

Hoshizaki Lancer Python Connection Details:

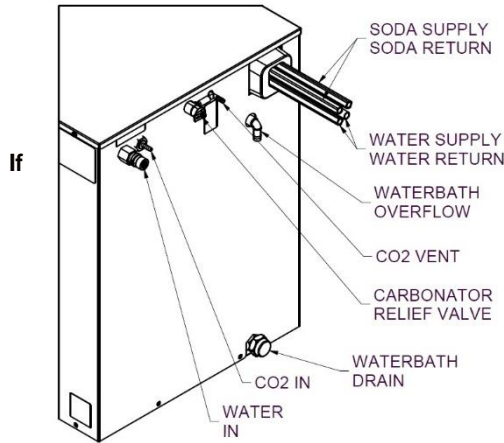

Python Tube Markings

Water Supply	Beige
Water Return	White
Soda Supply	Maroon
Soda Return	Black

Colour Stripe

Equipped With Syrup Coils:

1---1---1	Blue
2---2---2	Violet
3---3---3	Green
4---4---4	Yellow
5---5---5	Grey
6---6---6	Orange
7---7---7	Brown
8---8---8	Red

S4H SODA & WATER (IF EQUIPPED) RECIRCULATION SCHEMATIC

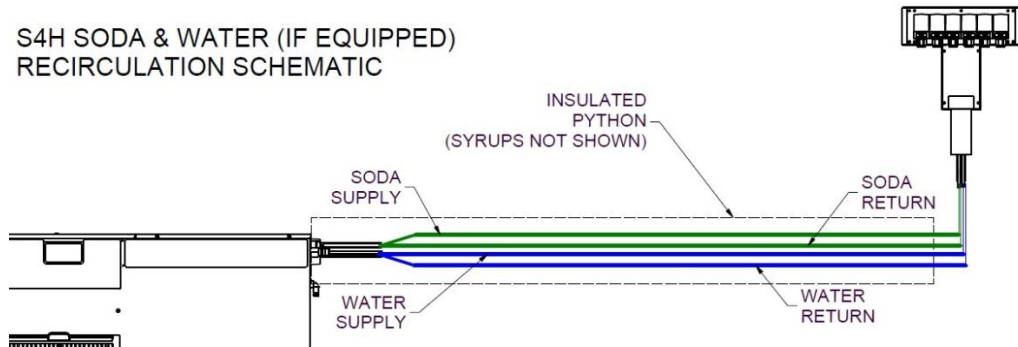

Ensure lines are insulated from python to Superchiller connections to prevent condensation.

Note: For additional Soda reserve on short python lengths used in high volume accounts, it may be necessary to extend the soda circuit by connecting 2 spare lines (if available) in the python onto the soda return line (i.e. double pass of soda circuit out and back from dispense point to soda return).

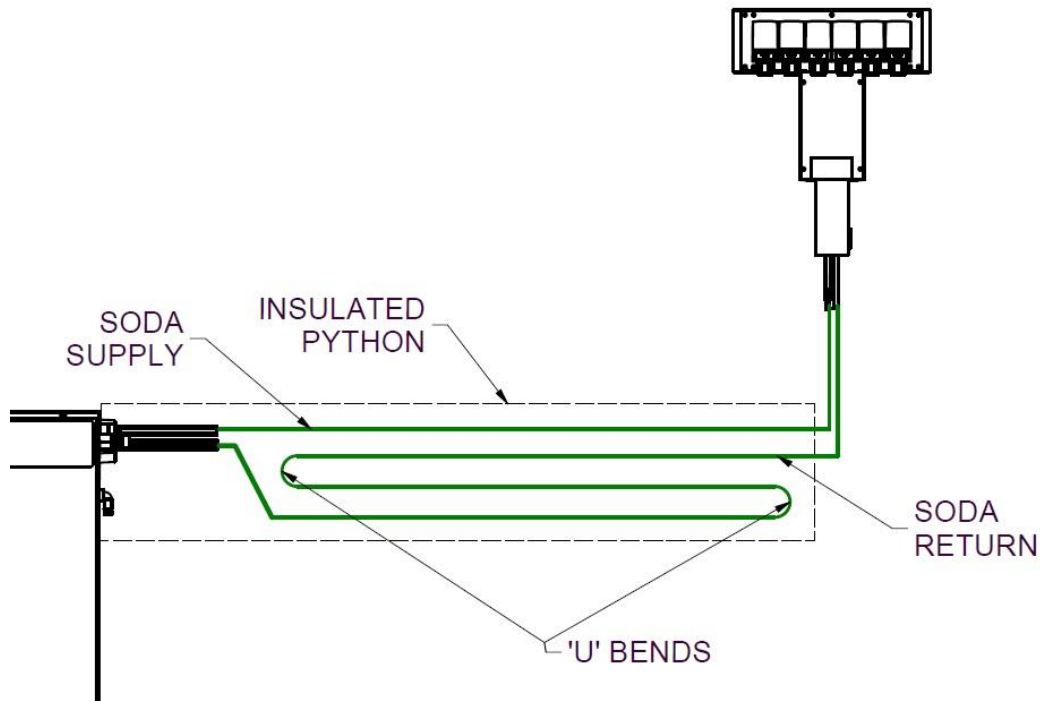

3.5 Connecting to water supply

- The appliance is intended to be permanently connected to a regulated water supply using appropriate tubing (10mm internal diameter minimum) and fittings connected to the Superchiller water supply inlet.
- A licensed plumber may be required to ensure the installation is in accordance with the local codes and regulations.
- Turn on the water supply, adjust water regulator to 345kPa (50psi) and check for leaks.
- Open the carbonator relief valve until water flows from CO2 exhaust tube; then close the relief valve.



Warning

The connections to the mains water supply must be made in accordance with the Plumbing Code of Australia and in accordance with AS / NZS 3500.1 and AS / NZS 3500.2. The dual check valve (backflow prevention) supplied with this unit must be connected between the main supply outlet and water inlet of appliance.



Caution

Recommended maximum water supply pressure 345Kpa (50psi)
Normal operating water temperature should be within 7°C to 35°C.

3.6 Plumbing the drain and CO2 exhaust

The 13mm overflow drain tube should be plumbed to a suitable drain, installation in accordance with the Plumbing Code of Australia and AS/NZS 3500.1 and AS/NZS 3500.2.

The 6mm barb labelled as CO2 EXHAUST should be plumbed to a well-ventilated safe outside area.

3.7 Connecting to CO2 Supply



Warning

As carbon dioxide (CO2) displaces oxygen; prevention of CO₂ leaks is paramount. If a leak is suspected, immediately ventilate the contaminated area, before attempting repairs.

- Connect CO2 supply line from regulator to gas inlet on carbonator.

- Adjust CO2 Regulator supplying Carbonator to 550kPa.
- Turn on CO2 supply and check connections for leaks.

3.8 Filling unit with water

	Warning	Disconnect the power before opening the top cover for filling the water bath. When filling the water tank, care must be taken to not splash water onto the electrical components
---	----------------	---

- Check that the Superchiller is unplugged from the mains electrical supply
- Remove the top panel.
- Fill the water tank with water up to the 'FILL LEVEL' marked on the inside of the tank.
- Refit the top panel

NOTE: Proper icebank control function depends on the conductivity of the water used. The Electrical Conductivity should be between 100 and 300 uS/cm. Below 100 uS/cm the compressor may not work properly, above 300 uS/cm the lines may freeze.

3.9 Electrical Connection

- It is recommended that the Superchiller is connected to a separate 230VAC 50Hz electrical supply, protected by an appropriate circuit breaker and Residual Current Device. Check the nameplate on the Superchiller for the electrical supply requirements.
- The service of a licensed electrician may be required to ensure the installation is in accordance with the local codes and regulations.

	Warning	To prevent possible electrical shock or extensive damage to the unit, the appliance must be connected with the flexible cord supplied with the appliance to an appropriate electrical outlet socket installed in accordance with local codes and regulations i.e. AS/NZS 3000.
---	----------------	---

	Warning	If the supply cord is damaged, it must be replaced by the manufacturer, its service agent or similarly qualified persons with a replacement cord available from Hoshizaki Parts/Service Centres.
---	----------------	---

3.10 Commissioning

- Ensure the Pump Switch is in the OFF position.
- Connect Superchiller power supply lead to an appropriate 3 pin socket outlet and switch the main power on. The condenser fan and agitator motor should start immediately. There is a 3-minute delay from initial power on before the compressor starts.
- The Power On and Waterbath > 5°C LED's on the front panel should be illuminated.
- The Waterbath > 5°C LED should go out approximately after 60-90 minutes.
- When the ice bank is fully formed (approx. 4 hours) the compressor will cycle off, but the agitator and fan will run continuously.
- After the Superchiller has cycled off, place the Pump Switch to the ON position to activate the carbonator and recirculation pumps.

3.11 Purge System

Progressively activate each dispensing valve or Bargun connected to the Superchiller systems until an uninterrupted flow of soda, water (where applicable), and syrup pours from each dispenser.

3.12 LED Display Panel

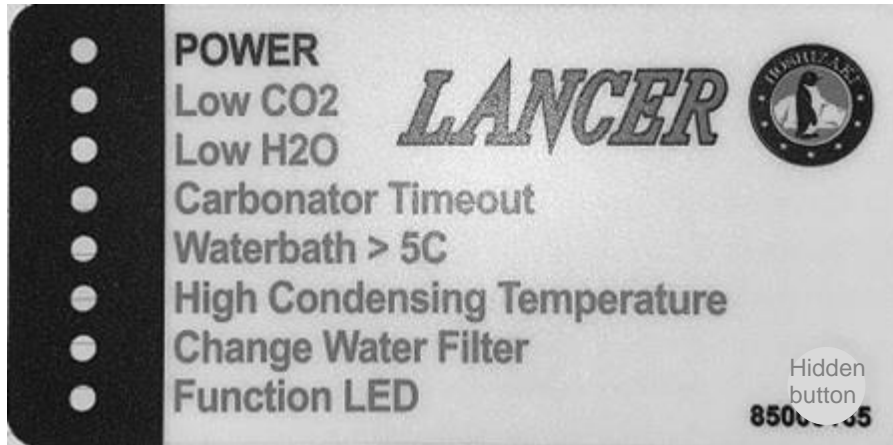

FUNCTION	DESCRIPTION
POWER	Indicates connection to mains utility. Is the only LED lit under normal operating conditions.
LOW CO2 (OPTIONAL)	If equipped indicates CO2 pressure has dropped below 415 kPa (60 psi) and in most cases indicates a depleted CO2 cylinder. Replace CO2 cylinder and check regulator set to 560 kPa (80 psi).
LOW H2O (OPTIONAL)	If equipped indicates incoming water pressure has dropped below 140 kPa (20 psi) for longer than 3 minutes and switched the pumps off. Check incoming water supply for closed cocks, pinched or blocked lines, dirty / clogged water filter etc.
CARBONATOR TIMEOUT	The carbonator has run past its timeout setting (default = 5 minutes). This may indicate a blockage, a water supply problem, broken pipe downstream or other related issue. Find and repair the problem. Cycle power at the wall to reset.
WATERBATH > 5C	Should remain off during normal operations. If illuminated then either there is an issue with the refrigeration, agitation or severe use over the capacity of the chiller. Investigate and resolve the issue.
HIGH CONDENSING TEMPERATURE	If yellow then unit is operating at the high end of its design capacity. If red then is operating at its upper design limit. If flashing red then has exceeded its design limit and shut down the refrigeration system. Possible causes are a dirty/blocked condenser, failed condenser fan, or ambient temperatures exceeding the design limits. Find and resolve the issues. Cycle power at the wall / power on switch to reset.
CHANGE WATER FILTER	There is an onboard timer that notifies the operator when approximately 1 year has elapsed since the last filter change. Check status of water filters and correct as required. Reset is by momentarily pushing a hidden button on the lower right side of the display panel.
FUNCTION LED	Possible freeze-up. Ice has grown over the temperature probe near the icebank control. Cycle Power On switch to reset.

4. Scheduled Maintenance



The following Superchiller routine maintenance should be performed at the intervals listed.

4.1 Daily

Cleaning/Sanitising

The Superchiller supplies soda water to the dispensing valves/barguns. To ensure optimum drink quality and system performance at all times please follow cleaning and sanitising procedures for the dispensing valves/barguns recommended by the valve/bargun manufacturer.

Maintain good food hygiene practices: Wipe up spills, throw away empty boxes and other rubbish, ensure proper stock rotation, remove and wash all dispensing nozzles, ensure work areas are clean and tidy.

Checking CO₂ Supply

Ensure that the contents gauge on the CO₂ Regulator reads higher than 1400kPa on the dial. If it does not, then the CO₂ cylinder is empty and must be changed using safe working practices.

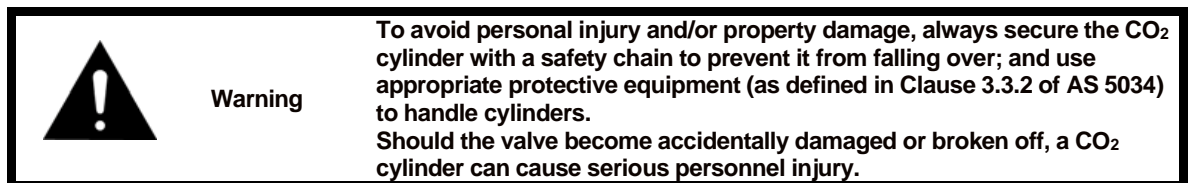

4.2 Quarterly

The Superchiller should be connected to a filtered water supply. To ensure optimum drink quality and system performance, water filters should be replaced at least yearly or more often depending on local water conditions.

4.3 Half Yearly

- Remove & Clean the condenser filter on the Superchiller. Clean condenser with low pressure compressed air. When using compressed air always direct air from the fan side through condenser. Remove all dust and foreign particles from refrigeration deck.



- Check that the waterbath level is between the Fill level and bottom of the overflow tube and the tube is not obstructed.
- Open carbonator relief valve to purge CO₂ and check leakage, close relief valve after checking.

4.4 Yearly

Water bath and recirculation pump inspection.

- Isolate Superchiller from power supply by switching off at socket.
- Thaw the bank of ice formed in the tank. Empty the water from the tank with a suction pump or drainage pipe.
- Inspect coils and agitator in water bath for algae or slime accumulation. Clean as necessary using a soft brush, rinse with clean water.

- Check recirculation pump strainers, if fitted, for accumulation and clean/replace if necessary.
- Check for build-up on and correct placement of Icebank Probe. Clean as required.

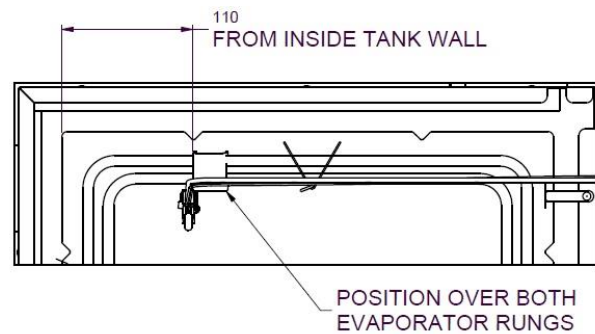
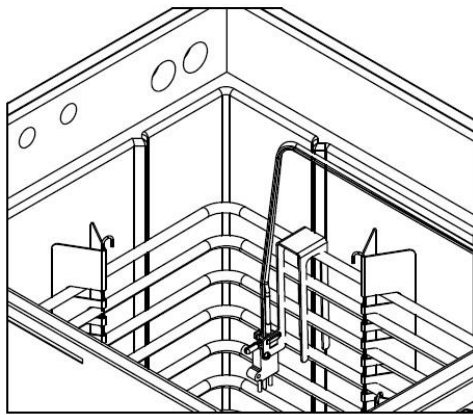

CORRECT PLACEMENT OF ICEBANK PROBE

- Fill tank with clean water until water to level indicated on the 'FILL LEVEL' plaque.
- Commission and purge system as per section 3.10 and 3.11 of this manual.

4.5 Sanitisation of Beverage System

To maintain optimum quality of dispensed product each Superchiller and its associated beverage system components must be thoroughly cleaned and sanitised annually.

Prepare sanitising solution

Prepare sanitising solution in accordance with the manufacturer's written recommendations and safety guidelines.

Do not use preparations with more than 200 ppm chlorine for longer than 30 minutes. Rinse thoroughly.

Sanitising BIB System

- Remove all disconnects from BIB containers.
- Immerse all disconnects in warm water and clean using a nylon bristle brush. Rinse with clean water.
- Prepare sanitising solution according to manufacturer's instructions.
- Attach sanitising fittings to BIB disconnects, if sanitising fittings are not available cut fittings from empty BIB bags.
- Immerse all sanitising fittings with attached BIB disconnects in bucket of sanitising solution. Operate all dispensing valves until the sanitising solution flows from the valve. Allow sanitiser to remain in lines for fifteen (15) minutes.
- Immerse all sanitising fittings with attached BIB disconnects in bucket of clean water. Operate all dispensing valves until all sanitiser has been flushed from the system.
- Remove sanitising fittings from BIB disconnects and re-connect disconnects to appropriate BIB's. Operate dispensing valves until syrup flows freely.

5. Diagrams & Parts

5.1 Postmix Assembly Diagram

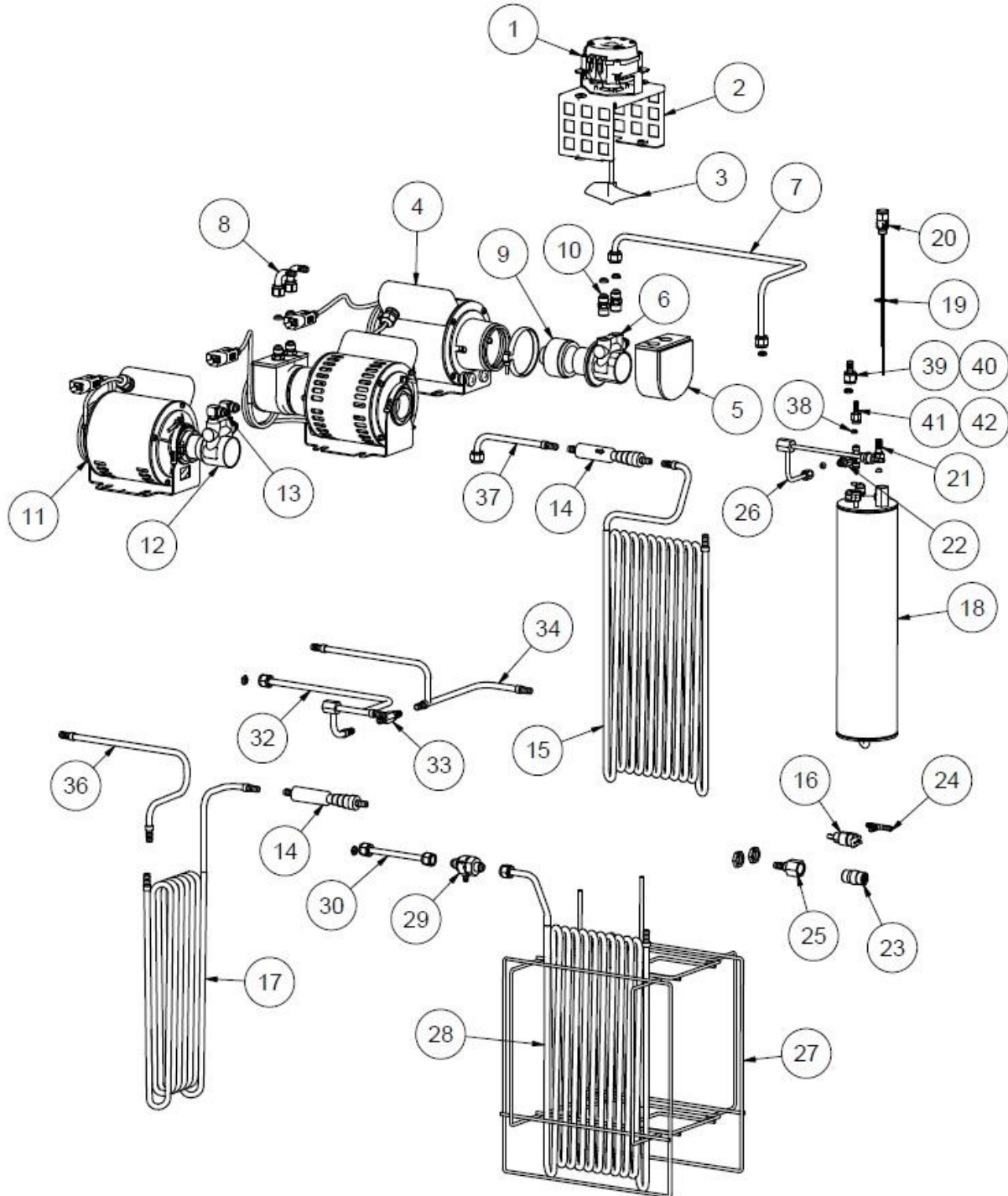

5.2 Postmix Parts List

Ref.	HL Part No.	Description
1	80000288	MOTOR ASSY AGI ECR1 IEC
2	61001170	BRACKET AGI S4H
3	87000144	BLADE AGITATOR 36119 X ¼ BSW
4	80000105	POSTMIX MOTOR MAG IEC PLUG
5	78000112	INSULATOR MAG PUMP
6	78000100	PUMP SS MAG WITH CLAMP
7	63001012	TUBE ASSY CARB OUT S4H
8	79000334	ELBOW SWIVEL 10MM X 3/8FL
9	78000110	DRIVE MAGNET
10	79000338	FITTING SS 3/8FL X 3/8NPT
11	80000106	MOTOR POSTMIX KEY IEC PLUG
12	78000101	PUMP BRASS WITH KEY
	78000019	DRIVE KEY PUMP PLASTIC
	78000018	V-CLAMP KEY PUMP
13	79000258	ELBOW SS PUMP
14	87000052	STRAINER FLOW INDICATOR
15	63001019	SODA COIL S4H
16	08000002	CARB RELIEF VALVE AS 5034
17	63001020	WATER COIL S4H
18	23000035	CARBONATOR LANCER 2.5L
19	23000022	CARB PROBE SEAL
20	23521975	PROBE CARBONATOR LP 2L LANCER
21	79000335	ELBOW SWIVEL 6MM X 1/4FL
22	16170469	FITTING ASSY CO2 FLARE
23	79000894	CHECK VALVE DUAL ½ BSP
24	79000316	TEE SS 6MM BARB
25	79001210	BULKHEAD FITTING 10MM X ½ BSP
26	63001013	TUBE ASSY GAS IN S4H
27	88000202	CRADLE S4H
28	63001021	PRECHILL COIL S4H
29	79000797	VENTED BFP 3/8 FL X 3/8 FL
30	63001011	TUBE ASSY BFP-PUMP S4H
31	63001015	TUBE ASSY WATER OUT S4H
32	63001017	TUBE ASSY WATER IN S4H
33	79000332	CHECK VALVE SS 10MM BARB
34	63001018	TUBE ASSY WATER RETURN S4H
35	61001263	COIL RETAINER 4W S4H
36	63001016	TUBE ASSY SODA RETURN S4H
37	63001014	TUBE ASSY SODA OUT S4H
38	79655294	FLARE SEAL MODIFIED YELLOW

5.3 Refrigeration Assembly Diagram

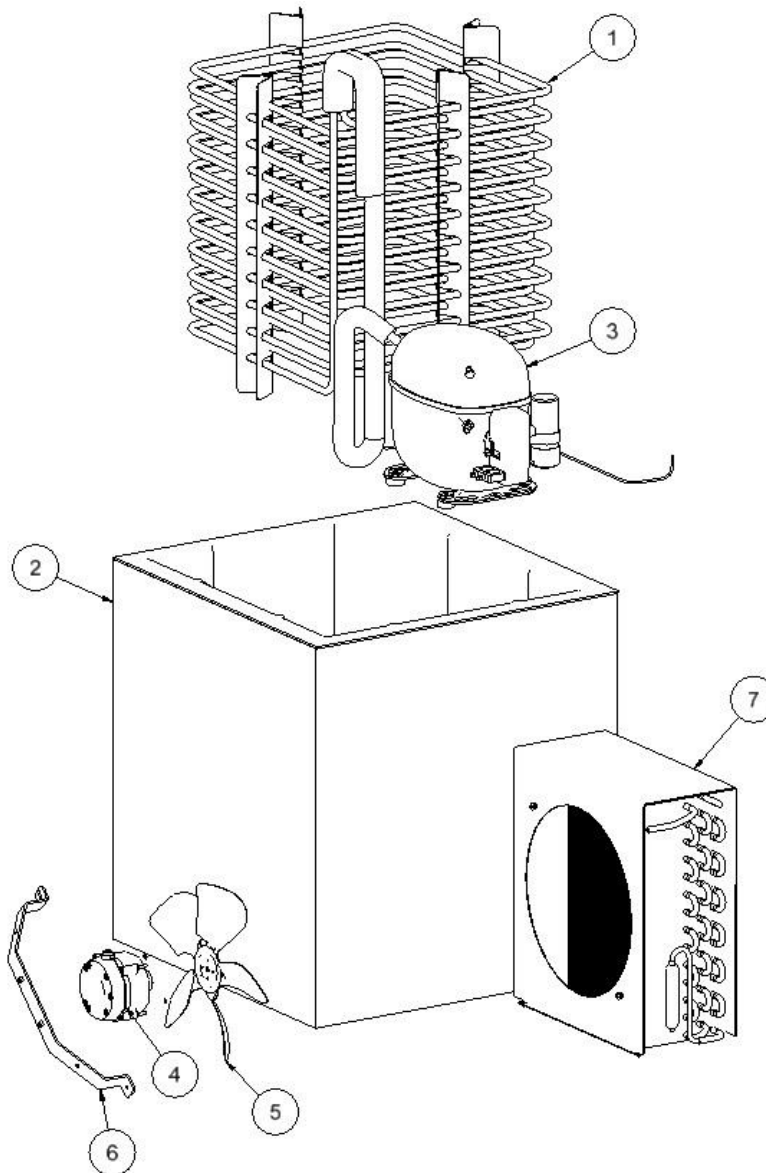

5.4 Refrigeration Parts List

Ref.	HL Part No.	Description
1	62000240	EVAPORATOR ASSY S4H
2	85000160	FOAMED TANK ASSY S4H
3	80000182	COMPRESSOR SCE18MNX
	80000186	CAPACITOR 80uF NLE11/SCE18
	80000188	START RELAY SCE18
4	80000192	FAN MOTOR 20W ECR1 650/1600 RPM
5	87000094	FAN 200MM V22
6	88000158	FAN BRACKET S2H
7	84000034	CONDENSER ASSY S4H

5.5 Electrical Assembly Diagram

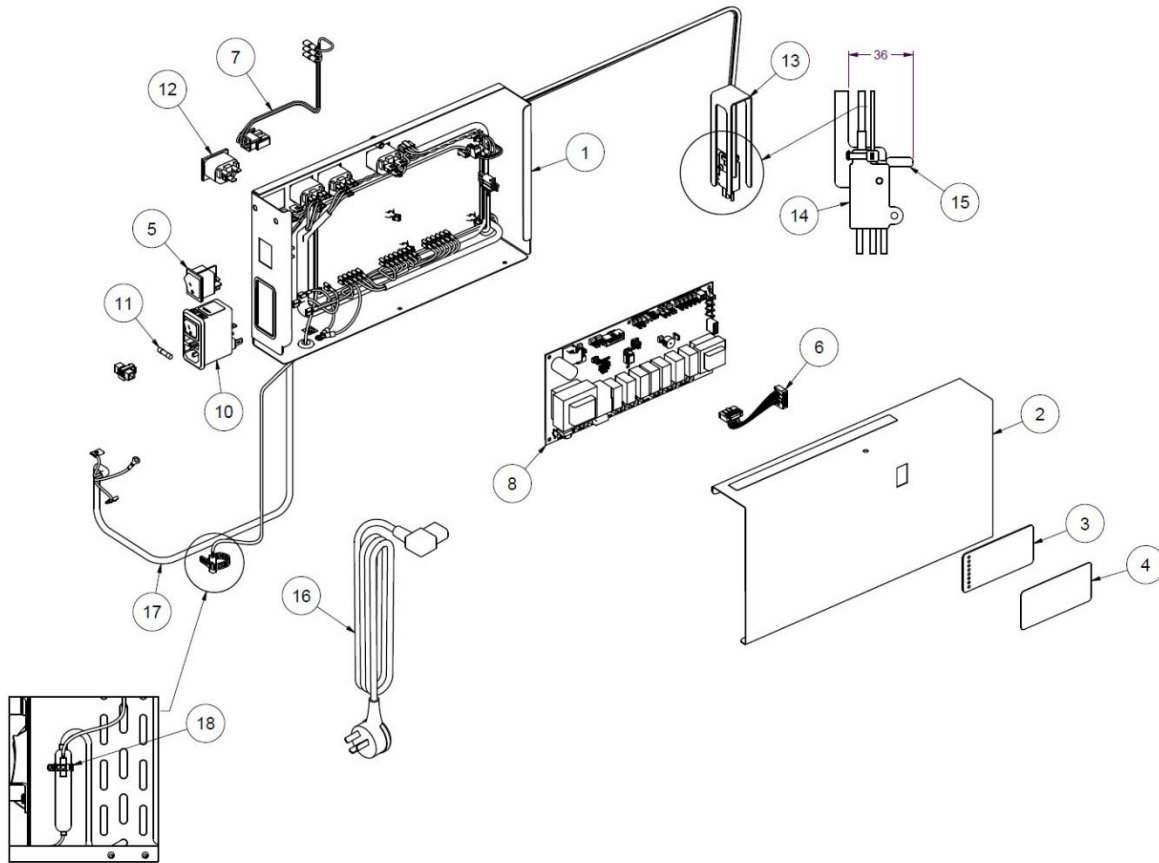

5.6 Electrical Parts List

Ref.	HL Part No.	Description
1	61001265	JUNCTION BOX BASE S4H
2	61001268	JUNCTION BOX LID S4H
3	83000471	DISPLAY PANEL OMNI EXTRA
4	85000164	LED PANEL FASCIA STANDARD
	85000165	LED PANEL FASCIA CO2 H2O
5	83000360	SWITCH ROCKER DPST
6	83000469	RIBBON CABLE OE DISPLAY
7	83601190	LEAD PROBE CONNECTOR TO LLC
8	83000470	CONTROLLER OMNI EXTRA
9	83000490	STRAPON NTC PROBE W/MOLEX
10	83000479	POWER INLET IEC W/EMF FILTER
11	83000504	FUSE 250V / 10A
12	83000211	SOCKET MAINS IEC
13	61001264	ICE PROBE BRACKET S4H
14	16522334	ICE PROBE LANCER
15	83000091	NTC PROBE
16	83000527	POWER LEAD IEC RIGHT 10A
17	83000489	HARNESS COMPRESSOR
18	83000490	PROBE STRAPON 0.7M

5.7 Body Panel Assembly Diagram

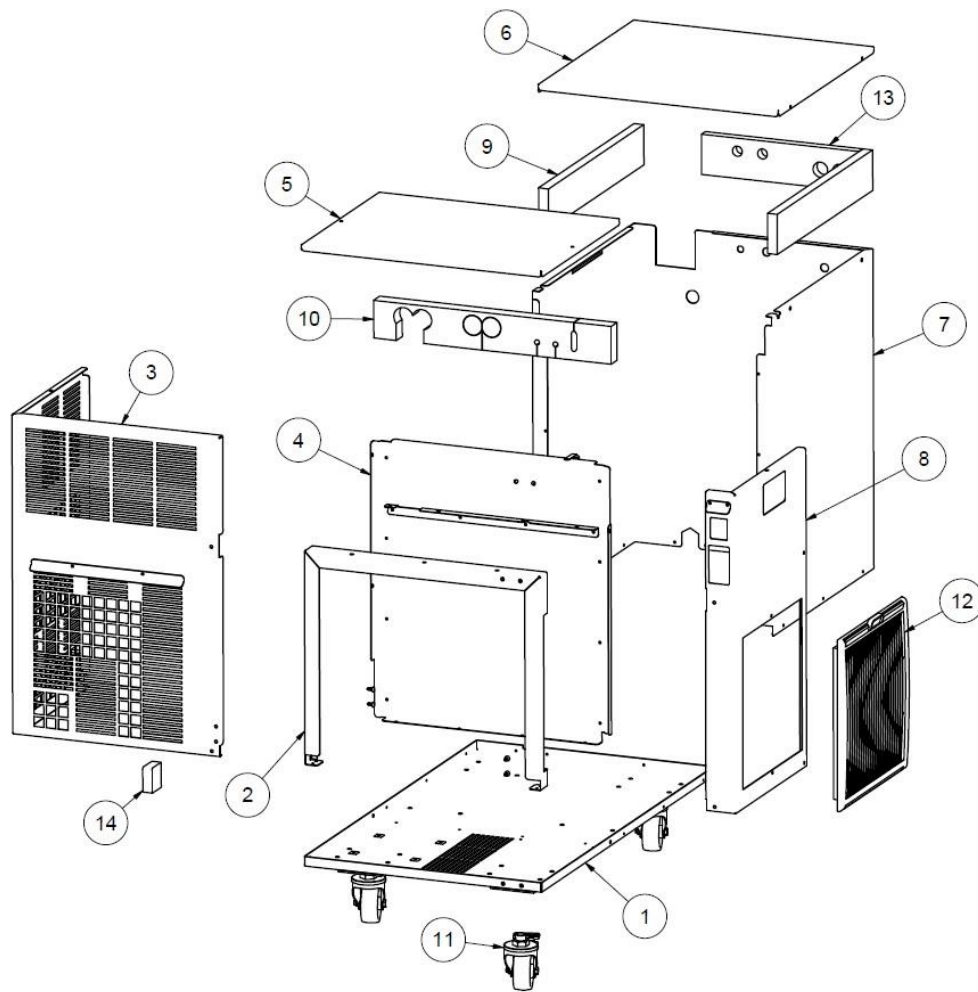

5.8 Body Panel Parts List

Ref.	HL Part No.	Description
1	61001261	BASE PANEL ASSY S4H
2	61001259	BRACKET PUMP DECK S4H
3	61001253	GRILL PANEL S4H
4	61001254	DIVIDER PANEL S4H
	61001256	BRACKET DIVIDER PANEL S4H LEFT
	61001255	BRACKET DIVIDER PANEL S4H RIGHT
	61001271	BRACKET DIVIDER PANEL S4H CENTRE
5	61001258	LID PUMP DECK S4H
6	61001257	LID WATERBATH S4H
7	61001260	MAIN WRAPPER S4H
8	61001252	FRONT PANEL S4H
9	61001262	TUBE HEADER S4H
10	79001230	BAFFLE DIVIDER PANEL S4H
11	79602411	CASTOR 75MM MANTOVA W/BRAKE
12	95001088	LOUVRE ASSY IM-130NE
	95000479	FILTER AIR IM130

5.9 Plumbing Diagram

S4H23 - WATER CIRCUIT

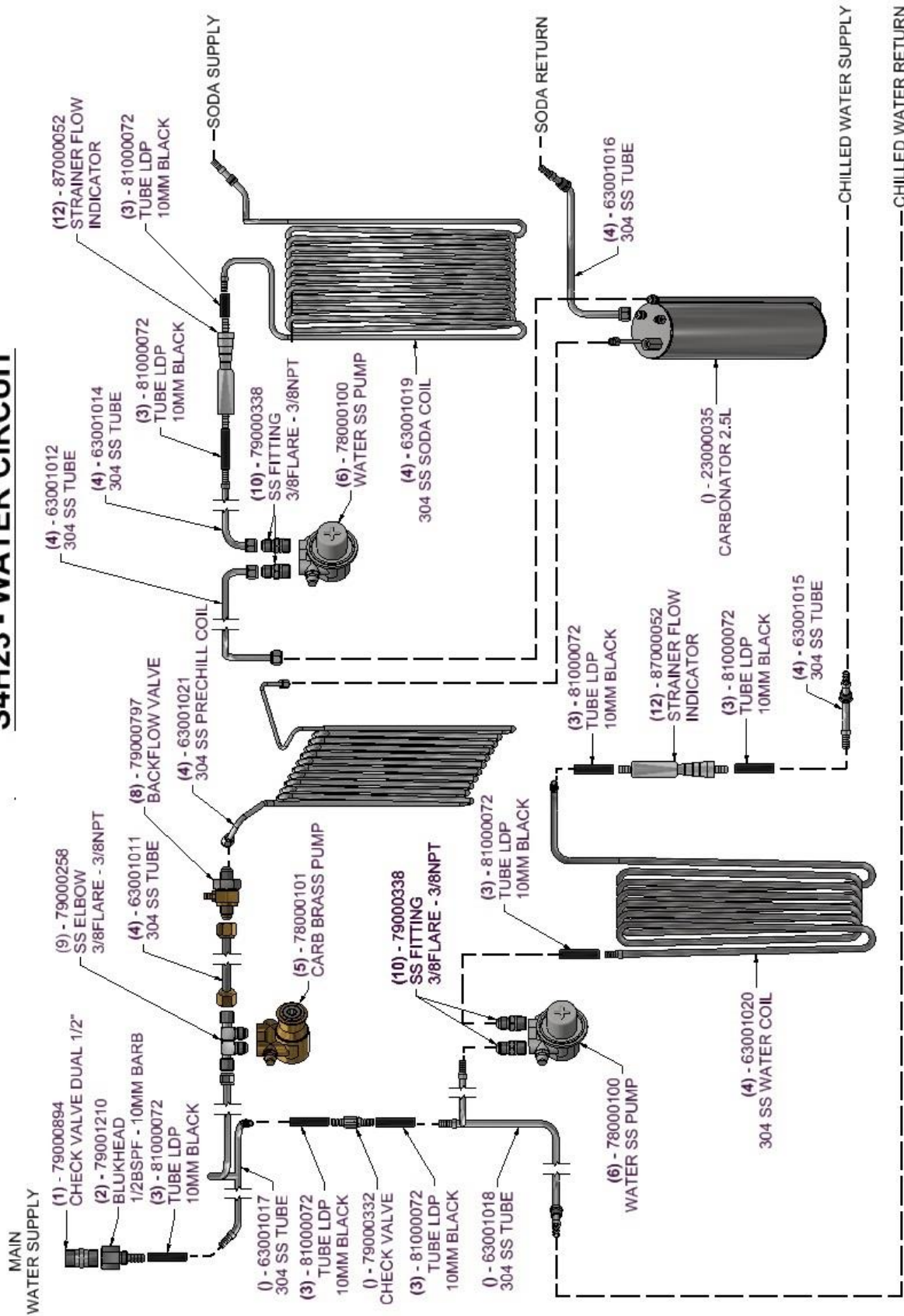

S4H22 - WATER CIRCUIT

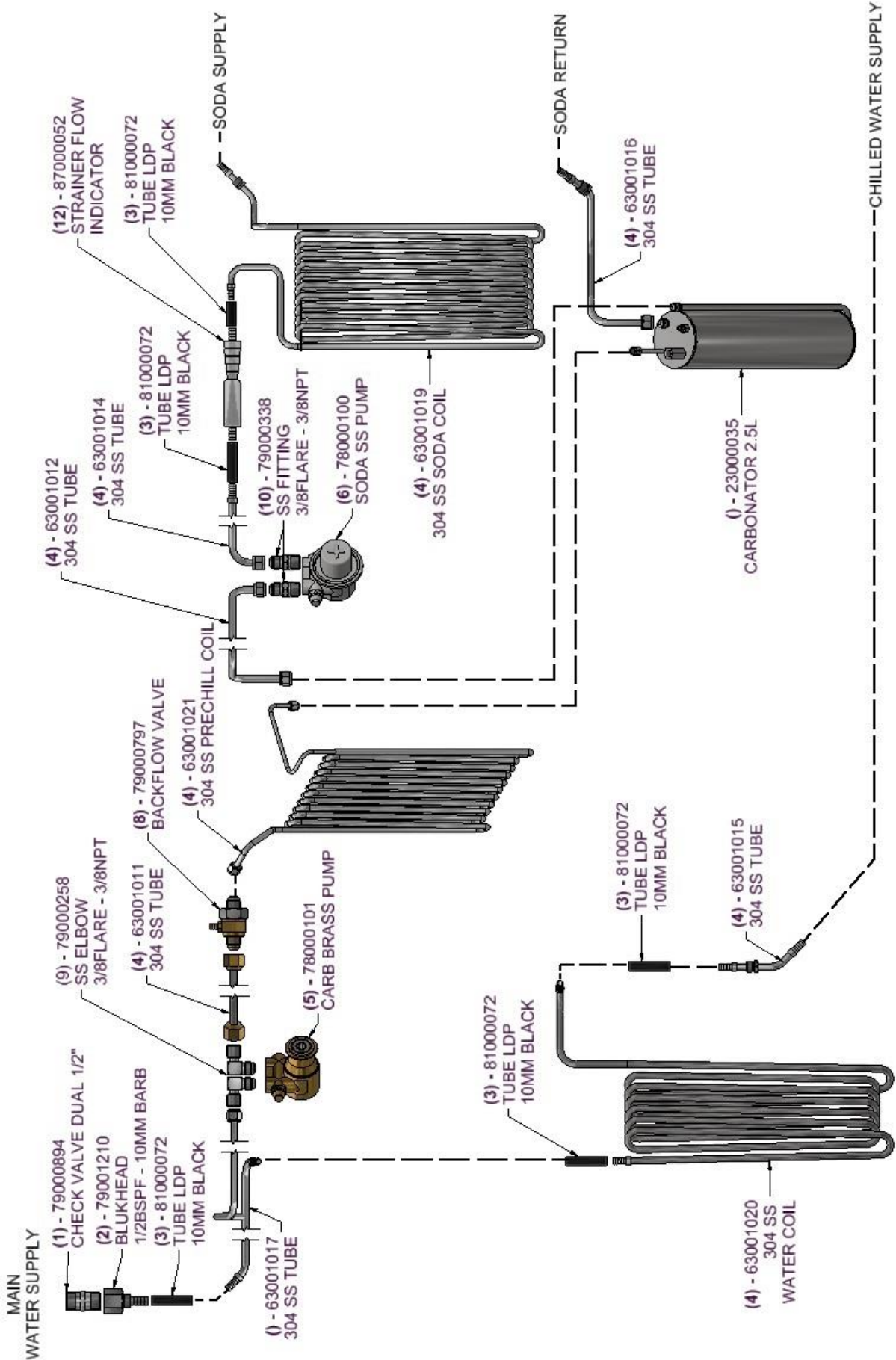

5.10 Wiring Diagram

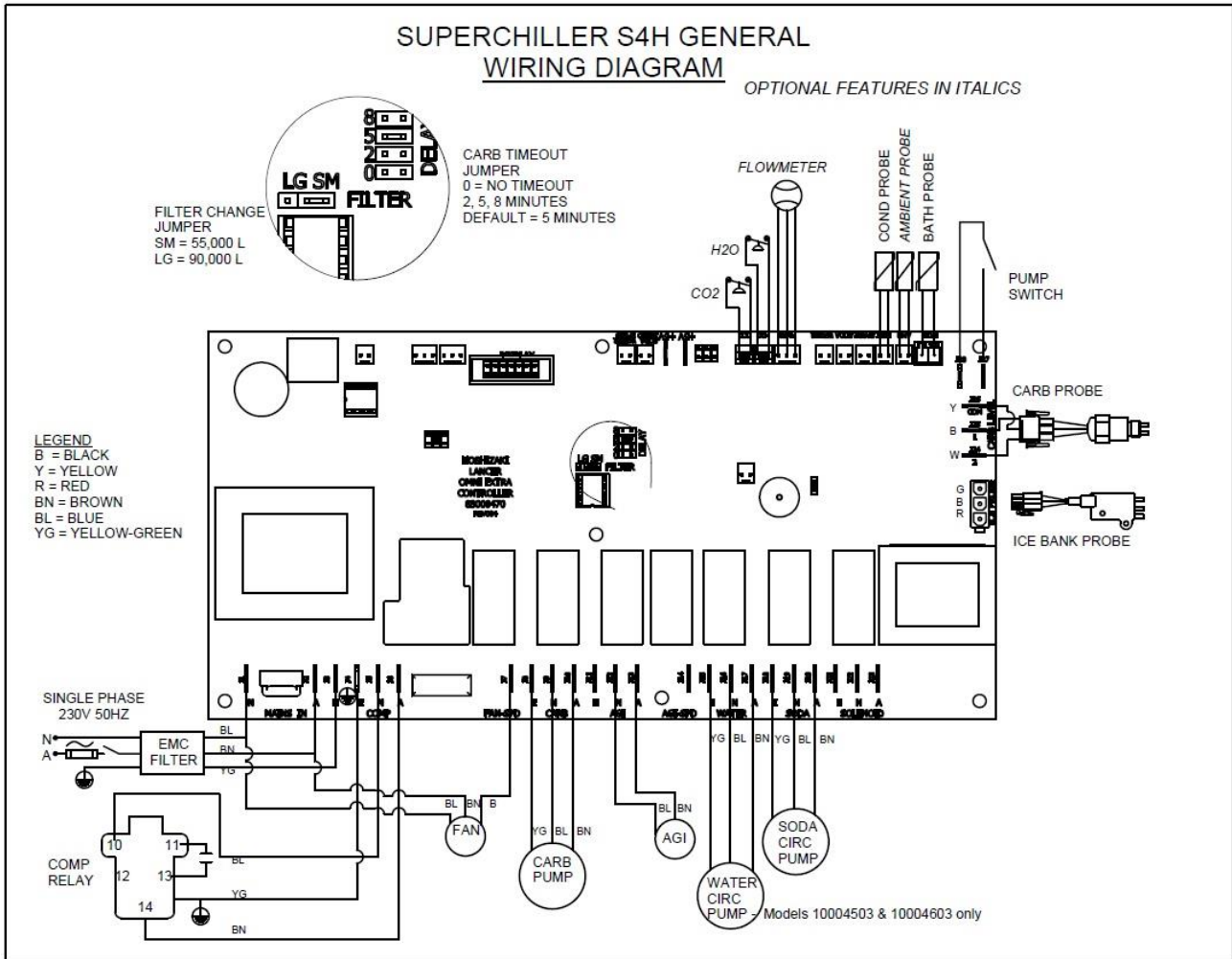

6. Trouble Shooting

Refrigeration

TROUBLE	CAUSE	REMEDY
Compressor will not start.	Power Failure.	Check for blown fuse, supply cord pulled out or supply turned off at wall or switch as applicable.
	High condensing temperatures (out on liquid line temp sensor).	Clean condenser/filter, air flow unobstructed, ventilate room if necessary. Check fan. Cycle power at the wall/switch to reset.
	Ice bank control faulty/ contacts not closing.	Check Ice bank control using Procedure 7.1. Replace control or probe if defective.
	Check compressor start mechanism components.	If faulty, replace e.g. capacitors, start relays.
	Internal overload faulty/ open circuit / compressor seized.	Replace compressor, check condenser, check power supply, evacuate system and if necessary fit burnout drier to industry standards.

TROUBLE	CAUSE	REMEDY
Compressor short cycling on internal overload (frequent starting and stopping of the compressor while ice bank control contacts remain closed).	Liquid line temperature probe failure. Dirty condenser. Restricted air flow over unit. Low supply voltage. Defective internal overload. Check wiring connections. Fan motor defective.	Check probe location and connection. Replace if necessary. Clean condenser of all lint and dirt. Check for air restriction to condenser. Check with voltmeter. Replace compressor. Tighten if loose. Replace motor.
Product too warm	Ice bank control defective (permanently open circuit). Low refrigerant charge. Check agitator motor, seized or fused.	Check Ice bank control using Procedure 7.1. Replace control or probe if defective. Leak check, repair leak, charge with correct amount of refrigerant. Replace if not working.
Compressor runs too long or doesn't cycle.	Location too hot. Superchiller overloaded. Defective ice bank control.	Relocate or improve ventilation. Use larger model, or reduce python length. Check Ice bank control using Procedure 7.1. Replace control or probe if defective.

Troubleshooting – Postmix

TROUBLE	CAUSE	REMEDY
Rusty appearance and/or metallic taste to water.	Poor water supply - contaminated.	Check with potable water filter specialist for remediation.
CO₂ gas or water escapes from pressure relief valve. (Observed from CO ₂ exhaust)	CO ₂ pressure too high. Failed carbonator probes – carb pump motor will not stop.	Check CO ₂ pressure relief valve. Bleed gas by opening and closing the relief valve - set to 550 kPa. Check carbonator control using Procedure 7.2. Replace control or probe if defective.
Carb pump times out. (LED on control panel illuminated).	Insufficient water supply. Higher than expected demand. Coil Freeze-up. Worn / defective pump. Failed carbonator / probe circuit.	Check filters, taps and supply tubing for blockages and rectify. Minimum water supply is 172 kPa flowing pressure. Move timeout jumper to next higher time interval. Defrost. Check Icebank controls and coil positions. Replace pump. Check carbonator control using procedure 7.2. Replace control or probe if defective.

TROUBLE	CAUSE	REMEDY
Poor carbonation (low CO₂ volume).	Flooded carbonator. Dirty water supply. CO ₂ pressure too low. CO ₂ inlet check valve stuck, shut or blocked. Poor quality paper cups. Dirty or greasy glasses. Improperly drawn drink.	Check carbonator control using Procedure 7.2. Replace control or probe if defective. Check filters. Check CO ₂ pressure at regulator. Should be set to 550 kPa., Repair or replace. Purchase better quality cups. Wash all glasses. Open faucet all the way and draw against side of glass or cup.
Pump leaks from shaft seal.	Worn pump seals.	Replace pump.
Pump(s) will not run.	Power failure or low voltage. Loose terminal connections. Defective relays. Defective motor. Locked up pump. Motor has cut out on overload. Faulty low pressure switch (if fitted). Carbonator flooded – filled completely with water. Carbonator empty - faulty Carbonator probe or control. Low water supply pressure. Excessive CO ₂ Pressure.	Check fuses. Check power supply. Check and secure. Check relays. Replace board if defective. Replace motor. Replace pump. Ensure of adequate water supply. Switch should close above 172 kPa. Replace if defective. Check mains water pressure - must be at least 135 kPa lower than CO ₂ (adjust water pressure regulator if necessary) Check CO ₂ regulator. Check carbonator control using Procedure 7.2. Replace control or probe if defective. Check carbonator control Using Procedure 7.2. Replace control or probe if defective. A minimum of 172 kPa water supply pressure is required Check function & setting of CO ₂ regulator.
Faucet delivers CO₂ gas continuously.	Insufficient water supply. Excessive carbonator CO ₂ pressure.	Check water supply and pumps for correct settings and operation. Check Carbonator CO ₂ pressure regulator for creeping. It should be set at 550 kPa.

7. Carbonator and Icebank Probe Tests

	Warning	230VAC is present on PC Board. Work should only be performed by fully trained & certified Electrical, Plumbing, & Refrigeration Technicians.
---	----------------	---

7.1 Icebank Probe Check

1. Remove the ice bank probe at the PC Board.

(Simulates water covering all probes)
2. Jumper the three terminals as shown. Use a spare male connector with wiring if available. The compressor relay should close and refrigeration system start.

(Simulates ice growth over green probe. Water still contacting red and black probes)
3. With refrigeration system operating (compressor relay energised) remove the jumper from the centre terminal. Refrigeration system should continue to operate.

(Simulates ice growth over the probes)
4. Remove the remaining jumper. The compressor relay should open and the refrigeration system should stop.

(Simulates ice growth over the probes)

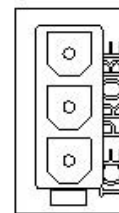
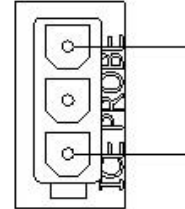
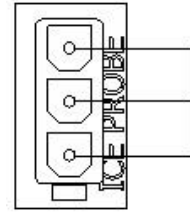

7.2 Carbonator Probe Check

Warning **230VAC is present on PC Board.**
Work should only be performed by fully trained & certified Electrical, Plumbing, & Refrigeration Technicians.

1. Remove the carbonator probe connections from terminals J24, J25 & J26. The carbonator pump relay should close.

(Simulates no water between ground (carbonator tank) and low level probe)
2. With carbonator pump operating connect alligator jumper from terminal J25 to terminal J26. Carbonator pump should continue to operate.

(Simulates water covering low level probe.)
3. With carbonator pump operating, connect alligator lead to terminal J24. Carbonator pump should stop.

(Simulates water over low & high level probes)
4. Carbonator pump will not restart until alligator clips are removed from J24 & J25.

(i.e. Water level drops below low level probe)

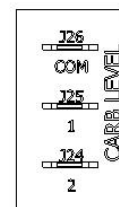
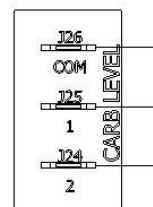
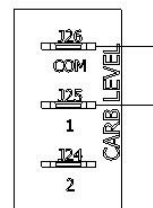
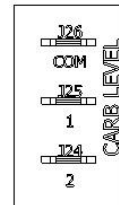

8. Certificate of Warranty

It is the policy of Hoshizaki to provide to its current customers, warranty for all equipment supplied and installation work performed within a specified period.

Parts and Equipment

Lancer provides a warranty period of twelve (12) months from the date of original invoice for all manufactured parts. Repair or replacement of defective parts will be at the sole discretion of Lancer.

Changeover parts will be invoiced to the customer at the customers normal purchase cost and upon return of the warranty item and validation of the claim, the invoice will be credited.

Installations

Lancer provides a warranty period of twelve (12) months from the date of final invoice for workmanship after the completion of any installation work, provided the parts and labour are completed by Lancer or its subcontractor.

Labour

Lancer will not normally cover any labour costs associated with a warranty claim. Subject to the approval of the Divisional Sales Manager, Lancer may choose to reimburse the customer for some or all labour costs associated with a warranty claim. Any claim for labour costs must be authorized by Lancer prior to the work being undertaken.

Exclusions

Lancer will not accept any liability or cost associated with any consequential losses (such as loss of syrup or beer), loss of profit or damage to property as a result of faulty product.

Warranty shall not apply:

- a) If in the opinion of Lancer, the equipment has been used in a situation the equipment has not been designed for;
- b) If in the opinion of Lancer, the equipment has been subject to abuse, negligence or accident;
- c) If connected to improper, inadequate or faulty power, water or drainage service or operated using incorrect, insufficient or contaminated lubricants, coolants, refrigerants or additives;
- d) Where the product is installed, maintained or operated otherwise than in accordance with the instructions supplied by Lancer;
- e) Where the product has been damaged by foreign objects;
- f) Where the product has been serviced, repaired, altered or moved otherwise than by Lancer or its nominees or using other than Lancer approved replacement parts.

To obtain full details of your warranty and approved service agency, please contact your dealer/supplier, or the nearest Hoshizaki Office.

Hoshizaki Lancer TEL: +61 8 8268 1388 FAX: +61 8 8268 1978

9. Manufacturer's Checklist

Checked by Date

Postmix Tested by

Gas Charge Icebank Probe fitted

Electrically tested by Refrigeration tested by

TAG No.....

- High temperature probe located midway on condenser.
- Refrigeration system final check. Ensure evaporator fully frosts.
- Check all tube work for rubbing e.g. discharge line, liquid line, capillary.
- Condenser not touching divider panel or grille.
- Agitator blades tight and not touching coils cradle.
- Overflow pipe correct height and positioned straight.
- All motors and pumps secured and mounted correctly.
- All pumps run quietly and carbonator pump switched O.K.
- Check icebank probe position and tightness.
- Carbonator and plumbing pressure tested.
- Check for leaks on pumps, clamps, welds, strainers, carbonator fittings and all joints.
- Coils in cradle correctly and spaced.
- Postmix tubes not rubbing.
- Plumbing strapped correctly and not touching the agitator.
- Tube labels on correct tube.
- Superchiller stickers correctly positioned and straight.
- Attention stickers fitted and correctly positioned.
- Clean exterior of unit including power cords.
- Condenser filters and alignment strips fitted.
- Warning stickers applied
- L.P. control operates (if equipped)
- Spreader pin pointing towards tank.
- Check body for sharp edges.
- Check lid for cleanliness and rough edges. Fit and secure.
- Carbonator relief valve fitted and correct.
- Copy checklist & file, put manual/checklist and pump insulator kit in plastic bag & place in the tank area.
- Customer asset No.



W/O