













Cooling more drinks, using less energy.

Introducing the **CED 800** with the latest technology for energy savings, sustainability, and the flexibility to offer carbonated and non-carbonated beverages.

Features

-  R290 Refrigerant
-  Reduced Energy Consumption
-  Eco-Smart Cooling
-  Available with 6 or 8 Post Mix Valves
-  Flexible Manifold Configuration
-  Removable Refrigeration Deck for Ease of Service
-  Stainless Steel Construction
-  Added Louvers for Ventilation
-  3/4 HP Compressor
-  3-Way Back Block

Accessories

Leg Kit

Options

Internal Cold Carbonation

External Carbonation

Internal Mini Syrup Pumps

Certified by these agencies:



CUSTOMER SERVICE

Should you require more information about our products, please do not hesitate to contact our customer service team at custserv@lancerworldwide.com.

WARRANTY

For warranty specifics by product, contact your Lancer Sales Representative. Equipment design and/or specifications are subject to change without notice.

For more information visit lancerworldwide.com or call 1-800-729-1500

One-Touch Flexible Carb to Non-Carb Dispensing

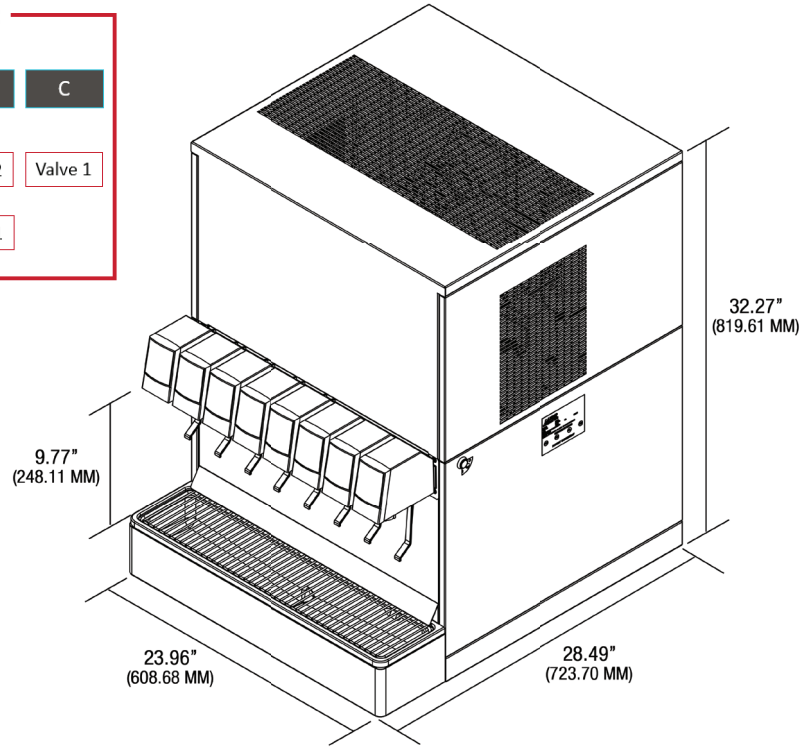
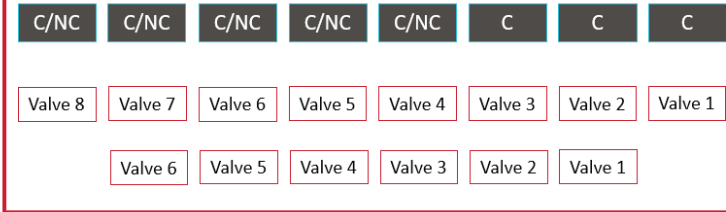

Dimensions

32.27" H x 23.96" W x 28.49" D
(819.61 mm H x 608.68 mm W x 723.70 mm D)



Weight

Empty: 220 lbs (99.8 kg)
Operating: 386 lbs (175 kg)
Shipping: 267 lbs (121 kg)



Ice Bank

Capacity: 50 lbs (23 kg)



Electrical

115V/60Hz, 15 Amps
220V/50Hz, 7.5 Amps
220V/60Hz, 7.5 Amps



Motor

Agitator : 25w
Condenser fan: 35w



Compressor

3/4 hp



Fittings

Plain Water inlet: 3/8" (9.5 mm) male flare
Syrup inlet: 3/8" (9.5 mm) male barb

For more information visit lancerworldwide.com or call 1-800-729-1500

6655 Lancer Boulevard • San Antonio, TX 78219 • 210-310-7000 • Fax: 210-310-7250 • © 2021 Lancer® Worldwide • Date: 2/23/2023

"Lancer" and "Lancer Worldwide" are trademarks of Lancer Corp. © 2021 by Lancer®, all rights reserved.