



The **2 coil inline heat exchanger** is so compact and light that it can be adapted to most under bar spaces.

FEATURES

- Complete Stainless Steel construction
- Has 2 x 6 Metre X 8mm O.D. 304 grade Product Coils with Push Fit Connectors.
- 12.5mm Barb Glycol Connections
- 25mm Insulation
- Compact and Lightweight - Stainless cover with mounting holes if required
- Unique Heat Exchange Technology
- Scope to loop product coils for single product ambient inlet.

CUSTOMER SERVICE

Should you require more information about our products, please do not hesitate to contact our customer service team at lancerservice@lancerworldwide.com



WARRANTY

For warranty specifics by product, contact your Lancer Sales Representative. Equipment design and/or specifications are subject to change without notice.

For more Information visit lancerbeverage.com or call +61 8 8268 1388

TECHNICAL DRAWINGS

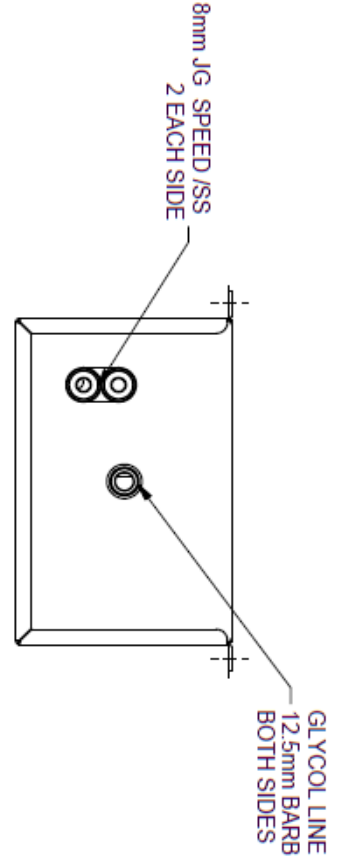
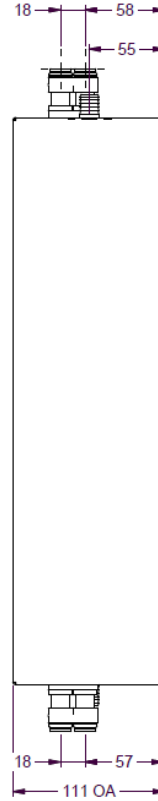
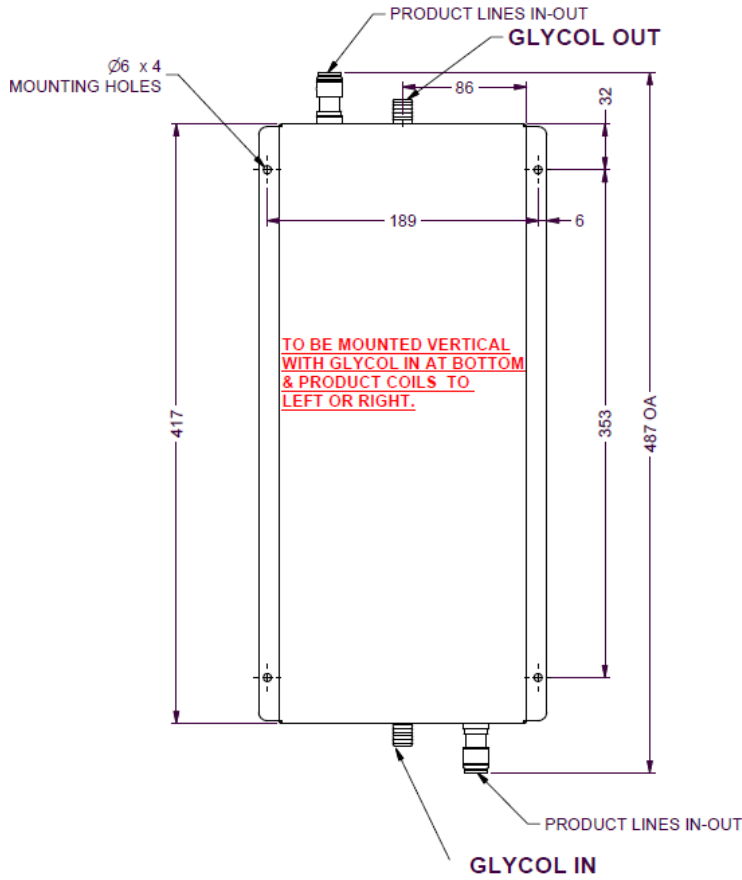

SPECIFICATIONS

Dimensions 485(W) x 201(D) x 111(H)

GLYCOL CIRCUIT

Coil Material 304 Stainless Steel

Working Pressure Max. 400kPa

Nominal Temperature -2°C

Recommended Flow Rate 6LPM

BEER CIRCUIT

Nominal Flow Rate 3.5 LPM

Max. Inlet Temperature 20.0°C

Working Pressure Max. 400kPa

For more Information visit lancerbeverage.com or call +61 8 8268 1388