



562

FBD Partnership, LP | +852.2369.3998 | sales@fbdfrozen.com | fbdfrozen.com

562 50HZ SPECIFICATIONS

DIMENSIONS

Countertop unit: Width: 432 mm (17.0 in)
Depth: 820 mm (32.3 in)
Height: 1,052 mm (41.4 in) (with merchandiser door)

CAPACITY:

Barrel size: 5,205 ml
Continuous draw: 67,428 ml/hour
Recovery time: 4 minutes

ELECTRICAL REQUIREMENTS:

230 VAC, 50 Hz, single phase, 3 wire, 20 Amp

REFRIGERATION:

14,300 BTU/Hr, R-404A (50Hz)

SPACE REQUIREMENT:

Sides and back: 51mm (2 in) minimum
Top: 305 mm (12 in) minimum

WEIGHT:

Operating unit: 156kg (345lb)

SYRUP CONNECTION

Bag-In-Box

MOTORS

Beater: (2) 120 W (1/6 HP)
Fan: (1) 135 W (1/5 HP)

WATER REQUIREMENTS

Fresh water, minimum 10mm (3/8 in) supply, 207 kPa (30 psi) flowing

OPTIONAL ACCESSORIES

Base cart (Part #12-22493-0001)
Leg kit (set of four) (Part #12-2533-0001)
Painted or stainless steel side panels
Water-cooled unit
Merchandiser options (see spec sheet)
Remote condenser (see spec sheet)
Bib Rack
Install Kit

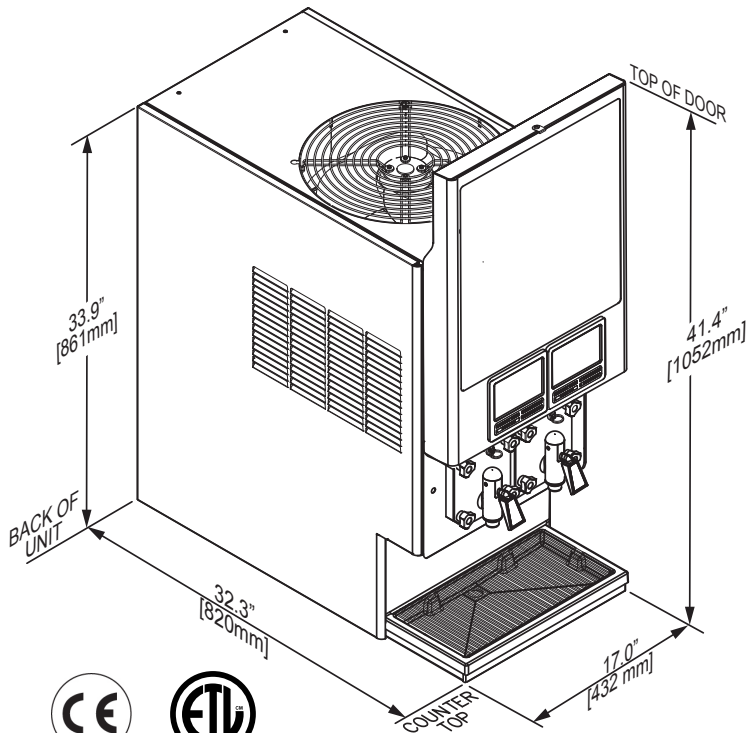

Intertek

562



Frozen Beverage Dispensers
EVERYONE LOVES FROZEN™

ROHS Compliant. FBD strives for continuous improvements and engineering innovations. Equipment design and/or specifications may change without notice. FBD - Frozen Beverage Dispensers • International Headquarters • Empire Centre • Unit #208A • 68 Moody Road • Tsing Sha Tsui East • Kowloon, Hong Kong • Office +852.2369.3998 • Fax: +852.2369.3983 • www.fbdfrozen.com • ©2012 FBD Partnership, LP. FBD®, the FBD logo, and "Everyone Loves Frozen™" are trademarks of FBD Partnership, LP, all rights reserved.



Frozen Beverage Dispensers
EVERYONE LOVES FROZEN™

562

PRODUCT FEATURES



- Inline Carbonation™ - creates a more consistent over-run, quality and yield
- AccuFreeze™ - maintains product consistency, delivering the most consistent frozen beverage, drink after drink
- RapidFreeze™ - cold chamber system improves recovery and draw-time, while reducing the compressor workload, and increasing dispenser durability
- Electronic Simplicity offers easy-to-use keypad interface
- Optimal Use of Counter Space with minimum ventilation of two inches side or back
- Scroll™ Compressor - provides more reliable operation, and fewer moving parts than reciprocating compressors
- Customizable individual barrels allows for hundreds of different drink profile combinations, including sugar free options

562

FBD Partnership, LP | +852.2369.3998 | sales@fbdfrozen.com | fbdfrozen.com