

LANCER | BEER SYSTEMS

Siberian™ Elite Glycol Chiller

220V / 60Hz

Installation, Operation & Service Manual



Table of contents

1.	Introduction.....	3
2.	The Company.....	3
3.	Our Products	3
4.	Product Details	4
	4.1 Product Features.....	4
	4.2 Specifications.....	4
	4.3 Options.....	5
5.	Installation.....	5
	5.1 Receiving	5
	5.2 Unpacking.....	5
	5.3 Selecting a Location.....	5
	5.4 Refrigeration Connection	6
	5.5 Connecting Glycol Lines	6
	5.6 Electrical Connection	6
	5.7 Filling Unit with Glycol / Water.....	7
	5.8 Commissioning.....	7
6.	Thermostat– Carell Pjexs – Thermostat Parameters.....	9
	6.1 Thermostat Settings.....	9
	6.2 Programming Instructions.....	10
	6.2.1 Set Point	10
	6.2.2 Other Parameters	10
	6.2.3 Eco Mode.....	10
	6.3 Alarm Signals	10
7.	Scheduled maintenance.....	11
	7.1 Monthly.....	11
8.	Trouble Shooting.....	12
9.	Electrical Diagram – Carel Thermostat.....	13
10.	Wiring Diagram – Carel Thermostat	14
11.	Spare Parts List	15
12.	Certificate of Warranty.....	16
13.	Manufacturer’s Checklist	17

1. Introduction

Thank you for purchasing this quality Hoshizaki Lancer product. All Lancer products are constructed using the highest quality materials and components. They are designed to the highest possible standards, therefore offering our customers endless hours of optimum performance.

2. The Company

Hoshizaki Lancer is a wholly owned subsidiary of Lancer Corporation, a world leader in the supply of Beverage Dispensing Equipment based in San Antonio, Texas. Lancer has manufacturing bases and distribution networks in 97 countries. Lancer is in turn ultimately owned by Hoshizaki Electric Co Ltd of Nagoya, Japan. Hoshizaki is a global leader in food service equipment.

Hoshizaki Lancer's head office and manufacturing base is located in Adelaide (SA), with branch offices and warehousing facilities in Sydney (NSW), Melbourne (VIC), Brisbane (QLD), Perth (WA) and Auckland (New Zealand).

3. Our Products

Hoshizaki Lancer specialises in the design, engineering, manufacture, and marketing of beverage dispensing and Heat Recovery equipment in three core categories:

Soft Drink Equipment

Mechanically cooled and ice cooled soft drink dispensers, frozen beverage dispensers, dispensing valves, carbonators and an extensive line of beverage dispensing parts and accessories.

Beer Equipment

Hoshizaki Lancer manufactures and markets beer dispensing and chilling equipment, and related accessories. Products include founts, chillers, Chillerplates, drip trays, taps, handles, beer line cleaning equipment and an extensive line of beverage dispensing parts and accessories.

Heat Recovery Equipment

Hoshizaki Lancer manufactures a range of Heat Recovery systems designed to provide our customers with free hot water.

4. Product Details

4.1 Product Features

The Hoshizaki Lancer Siberian™ system chiller is supplied with the following features as standard:

- Rotationally moulded inner & outer polypropylene tank offering long life and corrosion resistance
- The tank is insulated with environmentally responsible, water blown non-CFC polyurethane insulation
- A second thermostat probe is attached to the evaporator suction line. This probe will shut down the refrigeration system should the suction line temperature drop below normal operating conditions
- Air tight design of the tank & lid, keeps condensation to a minimum to eliminate dilution of the glycol solution
- Tank molded legs allow easy cleaning under the unit once installed
- Semi-submersible, single phase pumps
- Operates using environmentally responsible R404A refrigerant as standard
- Offers low installation, operating and maintenance costs due to single phase (220V 60Hz) power requirement to operate both the refrigeration and pump(s)
- CE Mark

NOTE: The Thermostat will not be energised unless the refrigeration control switch is turned on.

4.2 Specifications

Dimensions

Width	22.9 in
Depth	22.9 in
Height	54 in

Weight

Shipping	194 lbs
Empty	187 lbs
Operating	540 lbs

Refrigerant Connections

Suction Line	1.125 in
Liquid Line	0.375 in

Tank Capacity 42.3 gallons

Thermostat Carel PZLASNP001

Power Requirements Single Phase 220V / 60 Hz (amps dependent on pump configuration)

Max total head:

SPK 4-11/8	195 feet
------------	----------

4.3 Options

- Cooling Cassettes: 10243Btu/hr, 17072 Btu/hr, 27315 Btu/hr, 34144Btu/hr @ 14°F SST
- Glycol Manifolds complete with back check valves and ball valves
- Glycol refractometer
- External Glycol returns safety solenoid
- Adjustable Legs

5. Installation

5.1 Receiving

Each unit is tested and thoroughly inspected before shipment. At time of shipment, the carrier accepts the unit, and any claim for damages must be made with the carrier. Upon receiving units from the delivering carrier, carefully inspect carton for any visible indication of damage. If damage exists, have the carrier note this on the bill of lading and file a claim with the carrier.

**CAUTION**

To avoid personal injury or damage, do not attempt to lift the unit without help. Use of a mechanical lift is recommended.

5.2 Unpacking

Carefully unpack the Hoshizaki Lancer Siberian™ system chiller from the shipping carton.

5.3 Selecting a Location

- Unit is for indoor use only unless suitably protected by a weatherproof enclosure.
- The Hoshizaki Lancer Siberian™ system chiller should be located in a well-ventilated area that will allow easy access for servicing.
- Install on a flat, level surface. Level adjustments can be made on the adjustable legs. (Option)
- Ensure the maximum tilt of the machine does not exceed 2 degrees in any direction
- Should only be installed by a qualified and competent technician.
- This appliance is not intended for use by persons (including children) with reduced physical, sensory or mental capabilities, or lack of experience and knowledge, unless they have been given supervision or instruction concerning the use of the appliance by a person responsible for their safety.
- Children should be supervised to ensure that they do not play with the appliance.

5.4 Refrigeration Connection

- As with all installations, good refrigeration practice is necessary to ensure reliability and satisfactory performance of the Hoshizaki Lancer Siberian™ system chiller.
- All units have a holding charge of Nitrogen. Ensure the solenoid is active prior to evacuation. Failure to do so may result in poor evacuation of the refrigeration system and possible system failure.
- Solenoid can be activated by switching on mains control switch and making sure thermostat output is calling for refrigeration. It may be necessary to isolate pump to avoid excessive dry running during the evacuation procedure.
- Particular care should be taken to prevent oxidation during brazing, by using dry nitrogen and to ensure that a thorough evacuation of the system is carried out prior to gas charging.
- We recommend that isolating valves are fitted to the refrigerant pipes adjacent to the unit and that the refrigeration be connected to a dedicated and correctly sized condensing unit.
- Fully insulate suction line.

NOTE: REMEMBER ONE OF THE MAIN FACTORS AFFECTING EQUIPMENT RELIABILITY AND COMPRESSOR SERVICE LIFE IS CONTAMINATION.

Pollution of the liquid could occur due to leakage of lubricants (for submersible pumps and vertical wet pit pumps containing lubricants)

5.5 Connecting Glycol Lines

- Connect glycol lines from the manifolds to the Hoshizaki Lancer Siberian™ system chiller.
- Supply manifold direct to pump(s).
- Return manifold to glycol return pipe via return solenoid if required.
- After leak checking, ensure lines are fully insulated.



5.6 Electrical Connection

- This unit is connected to the supply via a NEMA 6-15 Plug and Cord set.
- Check the name plate on the machine for electrical supply requirements. Use only the power supply specified on the name plate.



WARNING

THIS UNIT MUST BE ELECTRICALLY GROUNDED (EARTHED) TO AVOID POSSIBLE FATAL ELECTRICAL SHOCK OR SERIOUS INJURY TO THE OPERATOR. ELECTRICAL CONNECTION MUST BE MADE IN ACCORDANCE WITH THE APPROPRIATE LOCAL CODES AND REGULATIONS.

	WARNING	IF THE SUPPLY CORD IS DAMAGED IT MUST BE REPLACED BY THE MANUFACTURER, IT'S SERVICE AGENT OR SIMILARLY QUALIFIED PERSONS IN ORDER TO AVOID A HAZARD
	CAUTION	IN ORDER TO AVOID A HAZARD DUE TO INADVERTENT RESETTING OF THE THERMAL CUTOUT, THIS APPLIANCE MUST NOT BE SUPPLIED THROUGH AN EXTERNAL SWITCHING DEVICE, SUCH AS A TIMER, OR CONNECTED TO A CIRCUIT THAT IS REGULARLY SWITCHED ON AND OFF BY THE UTILITY

5.7 Filling Unit with Glycol / Water

	CAUTION	ENSURE GLYCOL IS ADDED FIRST, THEN WATER, PRIOR TO STARTING THE REFRIGERATION SYSTEM – FAILURE TO DO SO WILL CAUSE SEVERE DAMAGE TO THE PLATE HEAT EXCHANGER AND REFRIGERATION SYSTEM, AND WILL VOID ALL WARRANTY
---	----------------	--

The Hoshizaki Lancer Siberian™ system chiller requires a 30% glycol / water mixture. Put 12.7 gallons of glycol in the tank and fill with water until the glycol / water mixture reaches the overflow.

The overflow should be plumbed away to a suitable drain or container, via a Goose neck connection.

	CAUTION	ONLY USE PROPYLENE GLYCOL FOR FREEZE POINT DEPRESSION. THE USE OF OTHER CHEMICALS MAY DAMAGE EQUIPMENT AND POSE A HEALTH RISK.
---	----------------	---

5.8 Commissioning

- Ensure refrigeration condensing unit is turned off to prevent heat exchanger plate becoming too cold and freezing glycol on initial return.
- Turn power on to the Hoshizaki Lancer Siberian™ system chiller.
- Turn pump(s) on and allow the glycol lines to fill. Ensure liquid level does not drop below pump intake during initial filling of glycol.
- As required, top up the unit with a premixed 30% glycol / water mixture to correct level.
- Check water / glycol mixture with refractometer.
- Turn on refrigeration condensing unit. If glycol bath temperature is above the set point of the thermostat the refrigeration solenoid should be operational.
- Check all connections for leaks.

- Monitor the indicated temperature on the thermostat and ensure temperature reduces to the set point.
- While the refrigeration system is operating, monitor the evaporator suction line temperature via the probe 2 by pressing and holding the Arrow down button. Record the lowest temperature and then set the AF parameter 9°F below this reading. This will ensure protection of the HX plate and refrigeration system in the event of a pump failure or freeze up.

NOTE:

1. The thermostat has a minimum compressor “OFF” time of 3 minutes to prevent short cycling. Temperature & differential settings should be such that the number of compressor starts does not exceed the manufacturers recommendations.
2. The Thermostat will not be energised unless the refrigeration control switch is turned on.

6. Thermostat– Carel Pjeasy – Thermostat Parameters



NOTE:

The Thermostat will not be energised unless the refrigeration switch is turned on.

6.1 Thermostat Settings

Parameter	Type	Def	Description
St	Set point	28	Refrigeration will turn off when glycol reaches this temperature.
rd	F	2.0	Temperature differential, glycol temperature will increase from the cut out point by this value before the refrigeration turns on.
AF	F	23	Antifreeze alarm set point. If the evaporator suction line reaches this temperature the control will stop the refrigeration system and will require a manual reset. Antifreeze alarm can be reset by holding “UP” and “DOWN” keys for 5 seconds. In case of probe 2 failure, the antifreeze alarm function is inhibited and regulation is still performed. If “AF parameter is set to its minimum value the alarm function is inhibited.
rt	F	**	Time (in hours) of max/min temperatures logging.
rH	F	**	Highest/ maximum recorded temperature.
rL	F	**	Lowest/ minimum recorded temperature.
AH	F	36.0	High temperature alarm (relative to set point).
AL	F	7.2	Low temperature alarm (relative to set point).
c2	F	3 mins	Minimum time in mins after turning off before the control will give an output to the refrigeration solenoid (short cycle protection).
r4	F	13.0	Value to increase the set point in ECO mode.
r2	F	41	Maximum allowed set point.
r1	F	23	Minimum allowed set point.

Controls programmed during manufacture.

All other non used parameters are hidden to avoid confusion.

6.2 Programming Instructions

6.2.1 Set Point

Push and hold the “SET” key, “st” is displayed then the current set point is displayed and flashes, release “SET” key to change the set point value.

Push the “UP” or “DOWN” arrow keys to change the set point value.

To accept the new value press the “SET” key or wait 60 seconds without pressing any keys for the unit to time out.

6.2.2 Other Parameters

Push and hold the “SET” key, until “rd” is displayed.

- Select the required parameter to change using the “UP” or “DOWN” arrow keys then press the “SET” key to display its value.
- Press the “UP” or “DOWN” key to change its value.
- Press the “SET” key to store the new value and move to the next parameter.

To exit from programming mode press the “SET” key for 3 seconds or wait 60 seconds without pressing any keys for the unit to time out.

6.2.3 Eco Mode

In the ECO mode an offset is added to the Set point: “St” + “r4”.

To set the ECO mode press and hold the “UP” key, “on” or “oF” is displayed showing how ECO mode will be changed, when “on” or “oF” disappears release key. In ECO mode “Ec” is displayed alternated to probe 1, Glycol temperature actual value.

6.3 Alarm Signals

When an alarm is activated, the display shows the corresponding message that flashes alternating with the temperature.

Message	Cause	Reset
“E0”	Glycol Probe Failure	Automatic
“E1”	Refrigeration Line Probe Failure	Automatic
“LO”	Low Temperature Alarm	Automatic
“HI”	High Temperature Alarm	Automatic
“AF”	Antifreeze Alarm	Manual Antifreeze alarm can be reset by holding “UP” and “DOWN” keys for 5 seconds.

7. Scheduled maintenance

7.1 Monthly

Check water/glycol level.

Check water/glycol concentration using refractometer (see chart).

Relative freeze points and refractometer readings for propylene glycol / water mix

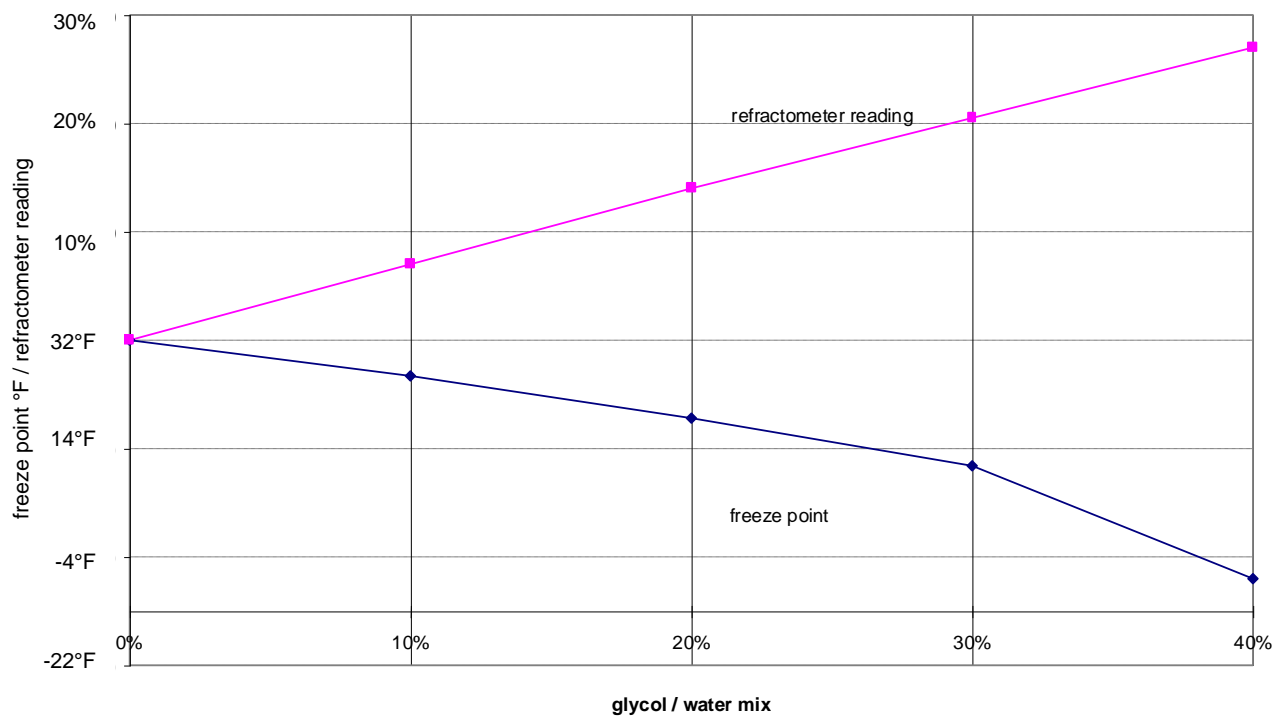

8. Trouble Shooting

TROUBLE	CAUSE	REMEDY
Condensing unit will not start.	Power Failure Pumps not active Thermostat probe failure Solenoid coil failure	Check for blown circuit breaker or cord pulled out. Replace Replace solenoid
Beer Warm	Glycol bath temp outside control set points Suction line hand valve(if fitted) is closed Faulty glycol pump Faulty TX valve Incorrect glycol concentration (poor agitation)	Check set points Open hand valve Replace pump Replace TX valve Check with refractometer & adjust
No product flow	Thermostat set too low Frozen product line	Adjust set point Switch off refrigeration while leaving pumps running & allow thawing. Some beers will freeze when set temp below 28 ^o f
Noise evident	Noisy pump	Replace/repair pump
No glycol flow	Frozen HX plate Low glycol level Low glycol %	Adjust set point System leak Add glycol

9. Electrical Diagram – Carel Thermostat

SIBERIAN ELECTRICAL CIRCUIT DIAGRAM

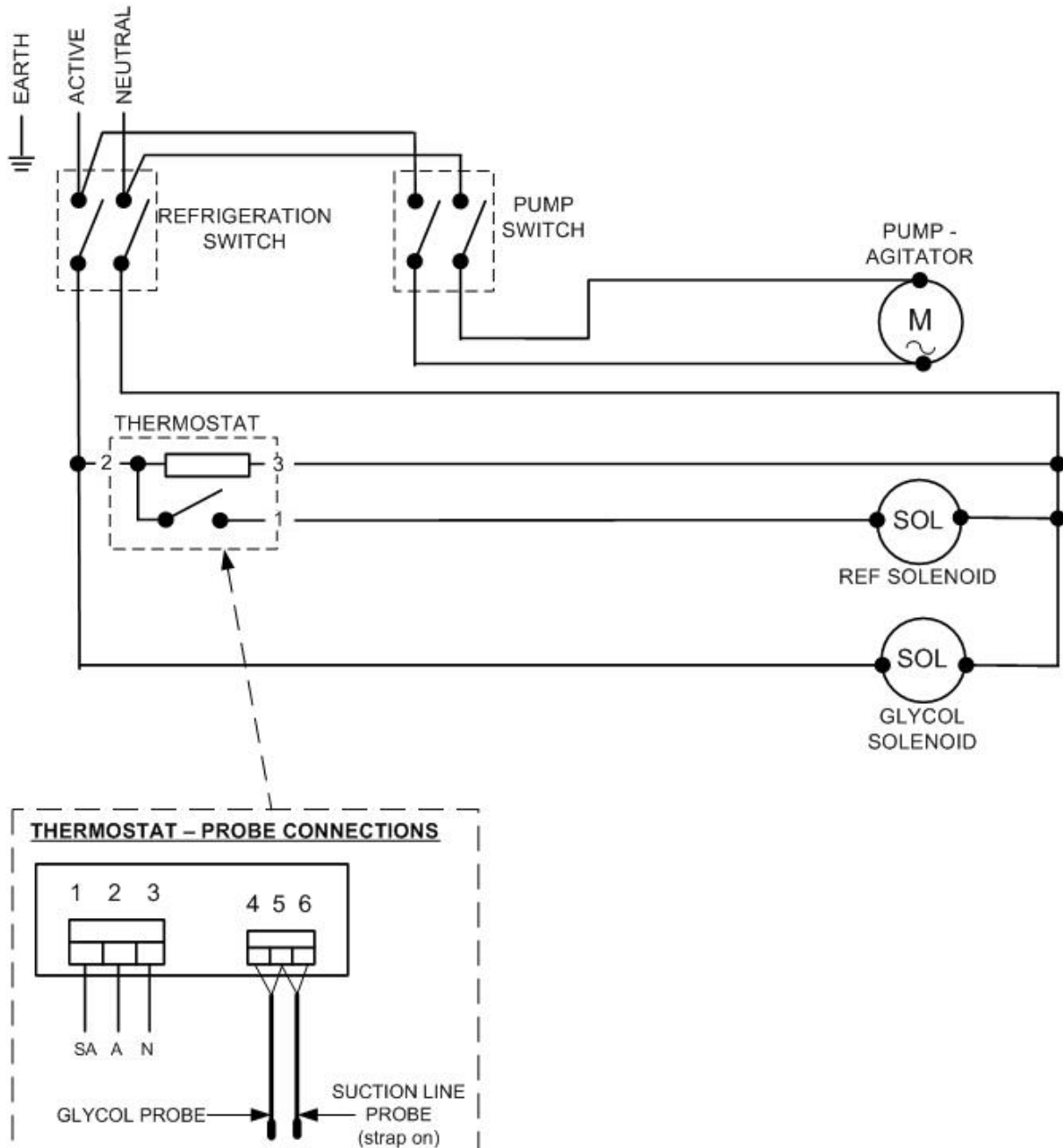

10. Wiring Diagram – Carel Thermostat

NTC PROBES

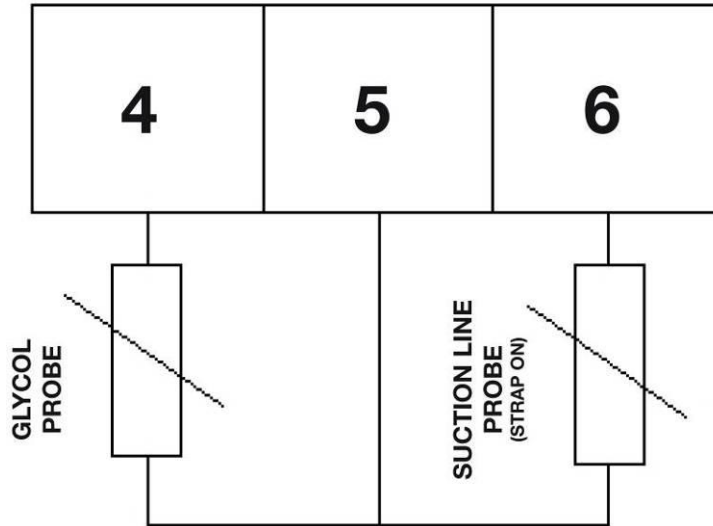

11. Spare Parts List

Ref	Parts No	Description
1	87000117	VALVE 2 WAY GLYCOL RETURN
2a	83000304	SOLENOID VALVE EVR3 – 5 kW
2b	83000351	SOLENOID VALVE EVR6 – 8 / 10 kW
3	83000305	COIL – SOLENOID VALVE
4a	85000099	LID SIBERIAN SPK4-11 1 PUMP
4b	85000108	LID SIBERIAN SPK4-11 2 PUMP
5	83000283	MAIN ELECTRICAL SUPPLY PLUG AND CABLE
6a	87600222	TX VALVE – 404A – 3 kW
6b	87600223	TX VALVE – 404A – 5 kW
6c	87600224	TX VALVE – 404A – 8 / 10kW
7	83000184	THERMOSTAT CAREL PJEASY
8	83000245	SWITCH ROCKER GREEN ILLUM
9	83000246	SEALING BOOT SWITCH ROCKER
10	83000350	SWITCH 16 AMP DPDT C/OFF
11	79000810	PUMP INSULATOR SPK 220 60
12	85000100	LID SIBERIAN INSPECTION USA

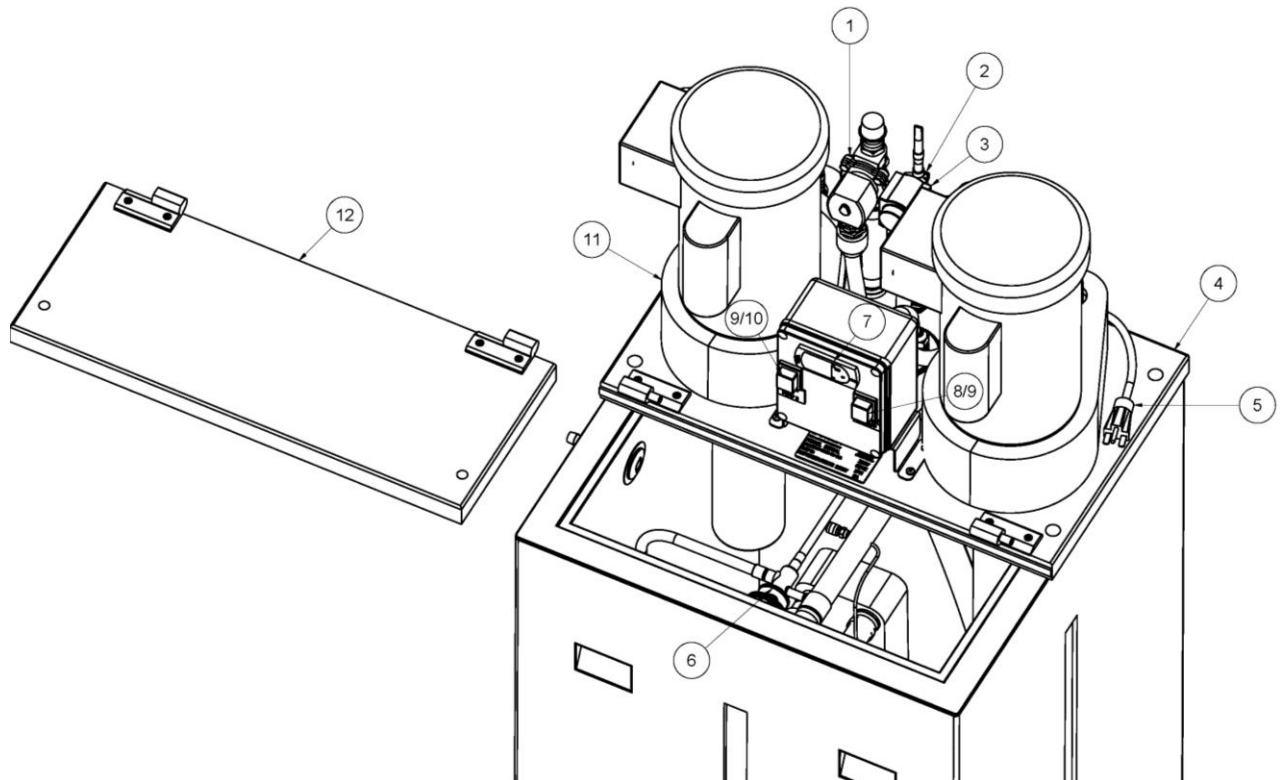

12. Certificate of Warranty

It is the policy of Hoshizaki to provide to its current customers, warranty for all equipment supplied and installation work performed within a specified period.

Parts and Equipment

Hoshizaki Lancer provides a warranty period of twelve (12) months from the date of original invoice for all manufactured parts and the associated labour. Repair or replace of defective parts will be at the sole discretion of Hoshizaki Lancer.

Changeover parts will be invoiced to the customer at the customers normal purchase cost and upon return of the warranty item and validation of the claim, the invoice will be credited.

Installations

Hoshizaki Lancer provides a warranty period of twelve (12) months from the date of final invoice for workmanship after the completion of any installation work, provided the parts and labour are completed by Hoshizaki Lancer or its sub-contractor.

Labour

Hoshizaki Lancer will not normally cover any labour costs associated with a warranty claim. Subject to the approval of the Divisional Sales Manager, Hoshizaki Lancer may choose to reimburse the customer for some or all labour costs associated with a warranty claim. Any claim for labour costs must be authorized by Hoshizaki Lancer prior to the work being undertaken

Exclusions

Hoshizaki Lancer will not accept any liability or cost associated with any consequential losses (such as loss of syrup or beer), loss of profit or damage to property as a result of faulty product.

Warranty shall not apply:

- a. If in the opinion of Hoshizaki Lancer, the equipment has been used in a situation the equipment has not been designed for;
- b. If in the opinion of Hoshizaki Lancer, the equipment has been subject to abuse, negligence or accident;
- c. If connected to improper, inadequate or faulty power, water or drainage service or operated using incorrect, insufficient or contaminated lubricants, coolants, refrigerants or additives;
- d. Where the product is installed, maintained or operated otherwise than in accordance with the instructions supplied by Hoshizaki Lancer;
- e. Where the product has been damaged by foreign objects;
- f. Where the product has been serviced, repaired, altered or moved otherwise than by Hoshizaki Lancer or its nominees or using other than Hoshizaki Lancer approved replacement parts.

13. Manufacturer's Checklist

- Evacuate, charge with nitrogen and leak check all refrigeration components.
- Liquid line and glycol solenoid installed in the correct flow direction.
- TX valve refrigerant matches unit.
- TX valve sensing bulb is secured tightly and in correct position, TX valve capillary not rubbing on anything.
- Air tape around TX bulb.
- Turn on unit, check thermostat operates and solenoids energise.
- Glycol probe in correct position and suction line probe checked for sensor tightness.
- Confirm operation of glycol probe, check for temp change. As per SOP-PRD-094
- Check pumps operate.
- Check wiring to ensure no internal insulation is exposed.
- All refrigeration tube work straight and not rubbing on other components.
- Installation kit supplied.
- Serial number plaque correctly positioned.
- Tank area clean.
- Supply manual.
- All screws secure, ensure deck and lid are fully sealed.
- Supply original checklist to unit, file copy.

Electrically Tested By:

Electrical Continuity

Inspection Number:

Earth Continuity

Insulation

Checked by:.....

Date:.....

Work Order No:

