



---

DRAFT BEER DISPENSER

# INSTRUCTION MANUAL

**DBF-25SB-AU**  
**DBF-43SB-AU**

L168QU111 (062012)

### IMPORTANT

1. This booklet is an integral and essential part of the product and should be kept and preserved by the user. Please read carefully the guidelines and warnings contained herein as they are intended to provide the installer/user with essential information for the proper installation and the continued safe use and maintenance of the product. Please preserve this booklet for any further consultation that may be necessary.
2. This is a draft beer dispenser, and should be destined only to be used for the purpose for which it has been expressly designed. Any other use should be considered improper and therefore dangerous. The manufacturer will not be held liable or responsible for any damage caused by improper, incorrect and unreasonable use.

## I. INSTALLATION

### WARNING

The installation must be carried out by qualified personnel, in accordance with current regulations, according to the manufacturer's instructions.

## 1. CONSTRUCTION

### [a] DISPENSER

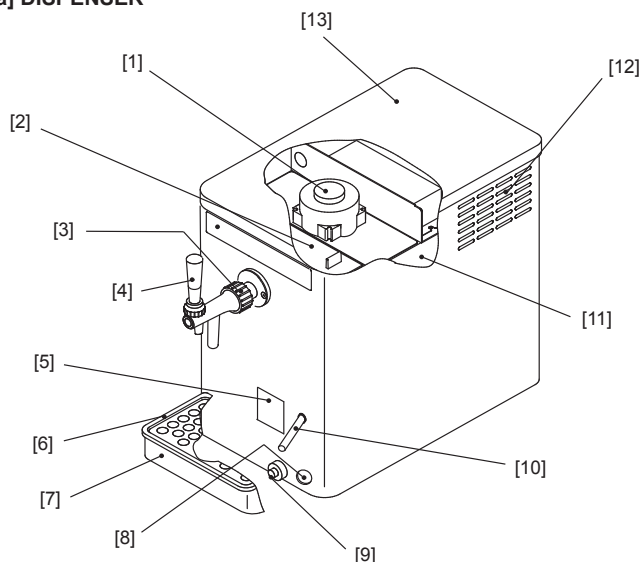

[1] Agitator motor  
Agitates cooling water in the water tank for effective cooling of beer.

[2] Inner cover

[3] Union nut

[4] Beer tap  
Pours beer into a mug.

[5] Nameplate

[6] Drain board (accessory)

[7] Drain pan (accessory)

[8] Beer inlet

[9] Drain outlet  
Drains cooling water from the water tank. Closed with a rubber plug.

[10] Overflow hose  
Maintains a constant level of cooling water in the water tank.

[11] Water tank  
Forms ice for beer cooling water.

[12] Machine compartment  
Contains refrigeration circuit and electrical components.

[13] Top cover

### [b] ACCESSORIES

Instruction manual	1 pc
Brush	1 pc
Cleaning sponge	6 pcs
Brush (S)	1 pc
Spanner	1 pc
Hook	1 pc
Hook mounting screw	2 pcs
Chain	1 pc
Beer hose adaptor	1 pc
Drain pan	1 pc
Drain board	1 pc
Nozzle cap	3 pcs
O-ring P10A	1 pc
O-ring P21	1 pc

## 2. UNPACKING AND LOCATION

### CAUTION

1. To prevent injury, wear work gloves and hold the bottom panel to carry the unit. Work in a pair or group.
2. The location should provide a firm and level foundation for the equipment to avoid the risk of water leaks or injury caused by overturn or fall.
3. To prevent possible damage or injury, do not hold the beer tap to carry the unit.
4. This unit is not intended for outdoor use. Exposure to rain may cause electric leakage or shock.

- 1) Inspect the package for damage. Any extensive damage found should be reported to the carrier.
- 2) After removing the packaging, remove the protective plastic film.
- 3) Check the exterior and interior parts for damage.
- 4) Check that all the accessories listed in "1. [b] ACCESSORIES" are included and not damaged.

### IMPORTANT

1. Normal operating ambient temperature should be within 5°C to 35°C.
2. Avoid a site where dripping is not allowed. In high humidity conditions, condensation on the exterior may drip onto the installation surfaces or floor.
3. The unit should not be located next to ovens, grills or other high heat producing equipment.
4. Allow 5 cm clearance at rear and sides for proper air circulation. Otherwise the cooling performance may reduce and electricity costs will increase.
5. Do not remove the labels.

## 3. ELECTRICAL CONNECTIONS

### WARNING

#### THIS APPLIANCE MUST BE EARTHED

This unit requires an earth that meets the national and local electrical code requirements. To prevent possible severe electrical shock to individuals or extensive damage to equipment, install a proper earth wire to the unit. Remove the plug from the mains socket before any maintenance, repairs or cleaning is undertaken.

- \* The main control box fuse is rated at 10A and should only be replaced by a qualified service engineer.
- \* Usually an electrical permit and services of a licensed electrician are required.
- \* If the supply cord is damaged, it must be replaced by a replacement cord available from Hoshizaki Parts/Service Centres.
- \* If the receptacle at the installation site is not earthed, use the screw at the rear of the unit to make an earth connection (an earth wire is not provided and should be prepared in the field).
- \* Do not connect the earth wire to a gas line, water line, lightning rod or telephone earth wire. Improper earthing may cause electric shock.

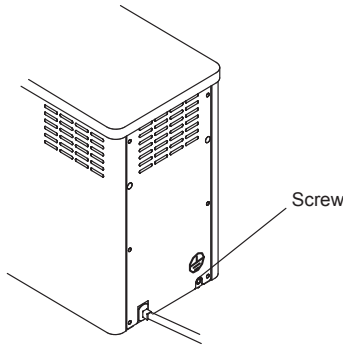

- [1] Quick gas hose joint
- [2] Beer hose adapter O-ring (P10A)
- [3] Quick beer hose joint
- [4] Beer hose
- [5] Keg coupler  
Dispenses beer out of the keg. Consult with the liquor shop or beer company, and prepare a suitable keg coupler for the keg to be used.
- [6] Beer keg
- [7] Gas hose
- [8] CO2 gas cylinder  
Contains CO2 gas to prevent beer from becoming flat and to push beer out of the keg. Consult with the liquor shop or beer company, and prepare a proper CO2 gas cylinder intended for use with beer.
- [9] Cylinder chain (accessory)  
Securely retain the CO2 gas cylinder on the fixed hook.
- [10] Hook (accessory)  
Mount on a firm base with the screws provided.
- [11] Regulator  
Adjusts CO2 gas pressure in the cylinder for proper beer dispensing. Consult with the liquor shop or beer company, and prepare the required regulator.

**IMPORTANT**

1. Check that the power cord is not caught by the unit legs or weighed down with heavy objects.
2. Unplug the unit by holding the attachment plug. To prevent damage, do not jerk the power cord.
3. Do not plug in or unplug the unit with wet hands.

**4. PLUMBING CONNECTIONS**

**IMPORTANT**

To sell draft keg beer, prepare and install the following equipment according to the instructions below.

**[a] CO2 GAS CYLINDER**

- 1) Open the main valve of the new CO2 gas cylinder for a second to splash moisture and dust from the joint. (Keep your face away from the cylinder.)
- 2) Check the regulator gasket. If it is out of position or damaged, gas may leak out.

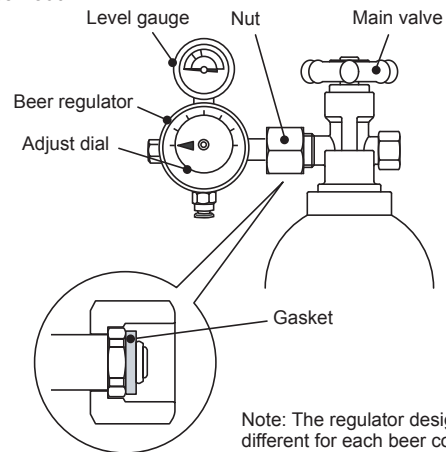

- 3) Install the regulator on the CO2 gas cylinder. Tighten the nut securely to a torque of 8 Nm so that the level gauge will be upright.
- 4) Open the main valve, and check the nut for gas leak (sound). If gas is leaking, retighten the nut.
- 5) After finishing the connections, turn the adjust dial to ensure proper pressure as listed below.

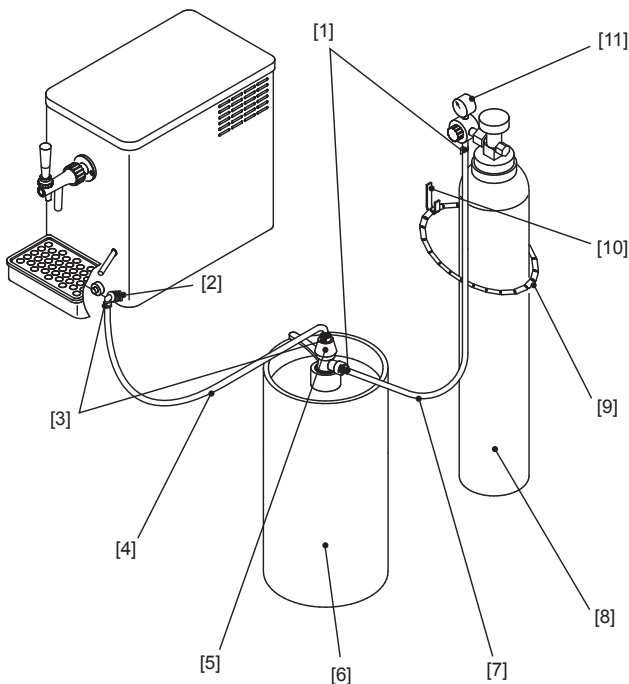

**IMPORTANT**

1. Handle the regulator with care to have no impact on it, or the pressure gauge may not read accurately.
2. Stand the CO2 gas cylinder upright, and fix it securely with the accessory chain.
3. Keep the CO2 gas cylinder away from direct sunlight or temperatures above 40°C.

## [b] PRESSURE RANGE

Adjust the CO<sub>2</sub> gas pressure to the following range (reference).

Beer keg temperature	Gas pressure
10°C	0.15 - 0.20 MPa (scale 1.5 - 2.0)
20°C	0.22 - 0.25 MPa (scale 2.2 - 2.5)
30°C	0.32 - 0.35 MPa (scale 3.2 - 3.5)

\* The appropriate keg pressure depends on the type and temperature of beer. Adjust the gas pressure according to the beer company's instructions. Insufficient pressure may result in excessive foaming.

## [c] EXTERNAL CO<sub>2</sub> GAS LINE

- 1) Determine the positions of the CO<sub>2</sub> gas cylinder and beer keg to make the gas hose length within 1.4 m.
- 2) Cut the gas hose to have a vertical cutting plane.
- 3) Insert the gas hose into the quick joints on the keg coupler and regulator. Pull the hose hard to check for tight connections.
- 4) Use the adjust dial to check for gas leaks.

### IMPORTANT

1. Cut the gas hose with a specialized tool such as hose cutter. Do not use scissors, or the gas hose may be crushed to cause gas leaks.
2. Do not disconnect and reinsert the gas hose. Cut it about 20 mm before reuse.
3. Cut the hose end vertically, insert it securely into the quick joints, and check for gas leaks.

### Quick gas hose joint

- 1) To insert the gas hose into the quick joint, push it all the way in.

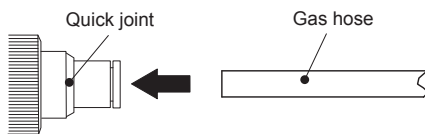

- 2) To disconnect the gas hose from the quick joint, push it with fingers as shown below and pull it out.

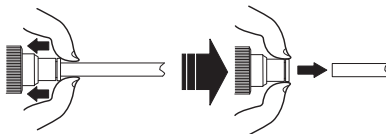

## [d] EXTERNAL BEER LINE

- 1) Attach the O-ring P10A (accessory) on the beer hose adapter (accessory), and install it on the beer inlet.
- 2) Attach the beer hose joint specified by the beer company on the beer hose adapter.
- 3) Determine the positions of the beer hose joint and beer keg to make the beer hose length within 2.1 m.
- 4) Cut the beer hose to have a vertical cutting plane.
- 5) Insert the beer hose into the quick joints on the keg coupler and quick beer hose joint. Pull the hose hard to check for tight connections.

### IMPORTANT

1. Cut the beer hose with a specialized tool such as hose cutter. Do not use scissors, or the beer hose may be crushed to cause beer leaks.
2. Do not disconnect and reinsert the beer hose. Cut it about 20 mm before reuse.
3. Cut the hose end vertically, insert it securely into the quick joints, and check for beer leaks.

## 5. TRIAL RUN

### [a] COOLING WATER SUPPLY

### IMPORTANT

When filling the water tank, be careful not to splash water onto the electrical parts.

- 1) Check that the unit is unplugged.
- 2) Remove the top cover and inner cover.

### 3) [DBF-25SB-AU]

Fill the water tank with tap water. The water tank overflows when the water level reaches about 2 cm below the top of the water tank. Then stop pouring water.

### [DBF-43SB-AU]

Fill the water tank with tap water up to the standard water level marked on the tank.



- 4) Refit the inner cover and top cover.
- 5) Plug in the unit.

### [b] CHECKS AFTER INSTALLATION

- \* Normal operating ambient temperature should be within 5°C to 35°C, and cooling water temperature within 5°C to 30°C. Do not install the unit where it could freeze. Operation outside of these normal temperature ranges may affect performance.
- \* Be sure to use tap water with a turbidity level of not more than 2. Use of well water or other non-tap water or mixture with salt, vinegar, or juice may cause inadequate ice storage, corrosion, or holes.
- \* The beer circuit has been cleaned before shipping. But clean it again before starting up the unit, and check for proper installation of each part.
- \* Check the power cord and hoses before starting up the unit.

### IMPORTANT

1. Do not install the unit where exposed to humidity or water splashes.
2. Do not remove the top cover or carry the unit with wet hands.
3. Be sure to unplug the unit before removing the top cover for cleaning or inspection.
4. Do not attempt to disassemble, repair, or modify the unit.

## II. OPERATION

### 1. CHECKS BEFORE OPERATION (DAILY)

#### [a] REPLACEMENT OF CO2 GAS CYLINDER

- 1) Close the main valve of the CO2 gas cylinder.
- 2) Adjust the regulator to "0".
- 3) Remove the empty regulator from the CO2 gas cylinder, and cap it.
- 4) Follow the steps 1) to 4) in "I. 4. [a] CO2 GAS CYLINDER".

#### IMPORTANT

Carry a CO2 gas cylinder with its cap on and without shaking.

#### [b] CHECKS AND REPLACEMENT OF BEER KEG

#### IMPORTANT

1. To prevent excessive foaming, do not roll or shake a beer keg. Handle it with care.
2. Excessive foaming is caused by a nearly empty beer keg. Replace it with a new keg as soon as possible.
3. When a beer keg becomes completely empty, CO2 gas will blow out of the beer tap and splash beer.
4. Do not store an open beer keg in a refrigerator. Keep it under 30°C.

- 1) Close the beer circuit.  
 Rotary type: Turn the keg coupler handle counterclockwise until it stops.  
 Vertical type: Unlock and lift the keg coupler handle all the way up.

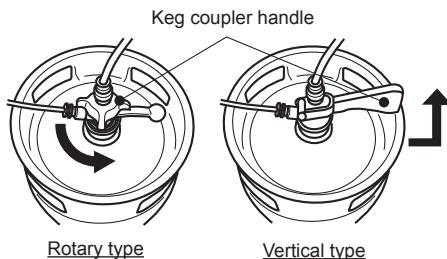

- 2) Turn the regulator adjust dial counterclockwise to "0".

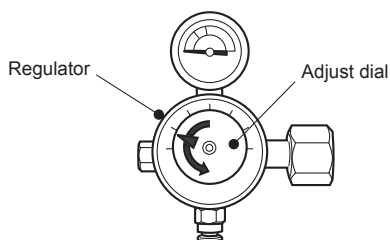

- 3) Turn the keg coupler counterclockwise, and remove it from the keg.

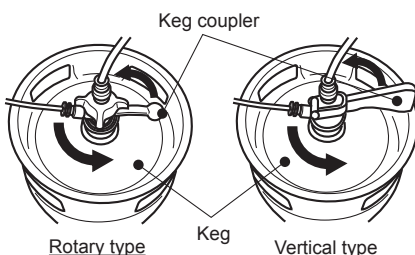

- 4) Attach the keg coupler on the new keg by turning it clockwise.

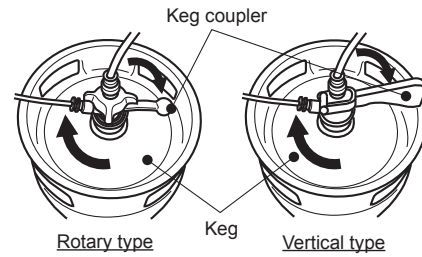

#### IMPORTANT

1. Wash the keg joint with water if necessary.
2. Do not loosen the ferrule on the keg.

- 5) Turn the regulator adjust dial clockwise to the appropriate gas pressure level specified by the beer company.

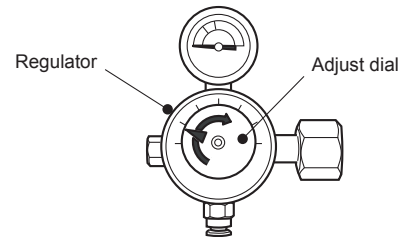

- 6) Open the beer circuit.  
 Rotary type: Turn the keg coupler handle clockwise until it stops.  
 Vertical type: Push down the keg coupler handle until it locks in place.

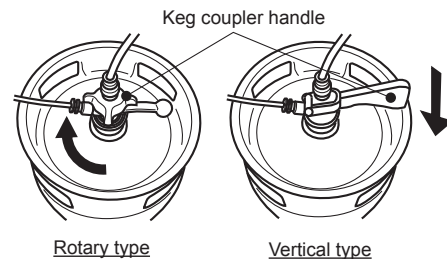

- 7) Before dispensing beer, lead beer to the beer tap according to "2. [b] LEADING BEER TO TAP".

## 2. DISPENSING

#### [a] BEER TAP OPERATION

- 1) To dispense beer, pull the beer tap lever quickly toward you until it stops. Moving the lever slowly or stopping it on the way will cause excessive foaming.

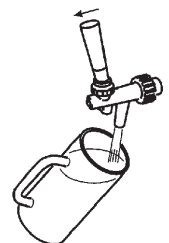

- 2) To stop beer, move the beer tap lever quickly back to its original position.



- To dispense foam, push the beer tap lever hard toward the unit from the stop position. To stop foam, move the lever back to its original position.



#### [b] LEADING BEER TO TAP

- Check that the regulator adjust dial is set to the appropriate pressure specified by the beer company.
- Check that the beer tap lever is closed. Opening the keg coupler with the beer tap lever open will cause beer to splash out.
- Open the keg coupler.
- Set a mug to receive beer, and push the beer tap lever hard to the back (foam position). Keep pushing it to dispense foam. When the mug is half filled with foam, move the lever back to its original position to stop foam.
- Wait for more than 1 minute after step 4) to settle beer in the circuit.
- Set another mug, and pull the beer tap lever toward you to dispense beer. Keep dispensing beer until foam turns into liquid.
- Check the keg coupler and keg connection and the beer hose joints for beer leaks.

#### IMPORTANT

Frequently dump water and beer from the drain pan. The cooling water in the water tank will increase in volume by taking moisture from the air, and come out through the overflow hose into the drain pan. If left as is, water will flow out of the drain pan onto the floor.

#### [c] DISPENSING BEER

- Tilt a clean mug at an angle of 45°, and place its inner surface in contact with the liquid nozzle of the beer tap.

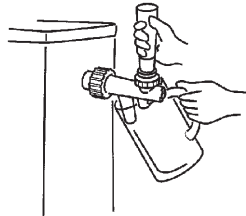

- Pull the beer tap lever toward you to dispense beer over the inner surface of the mug.

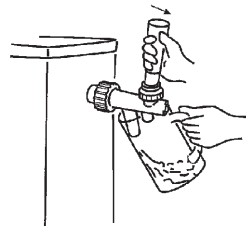

- After dispensing a specific amount of beer, move the beer tap lever back to its original position to stop beer.

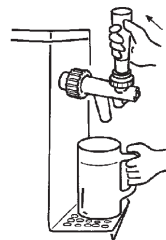

- To add foam, push the beer tap lever to the back. Foam will keep coming out of the foam nozzle of the beer tap while the lever is pushed. To stop foam, move the lever back to its original position.

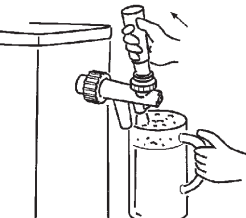

#### IMPORTANT

If the beer circuit is not flushed with beer remaining on the beer tap, the valve shaft jams inside the beer tap, resulting in unavailable, unstable, or continuous dispensing actions. In this case, disassemble and clean the beer tap in accordance with "III. 5. DISASSEMBLY AND CLEANING OF BEER TAP (WEEKLY)".

#### [d] END OF OPERATION

- Close the keg coupler, and remove it from the keg. Flush the beer circuit according to "III. 1. BEER CIRCUIT (DAILY)" and "III. 4. CLEANING BEER CIRCUIT WITH SPONGE (WEEKLY)".
- Turn the regulator adjust dial counterclockwise to "0".
- Shut off the CO2 gas cylinder by turning the main valve clockwise.
- Wipe moisture from the nozzle end. Wash the nozzle cap clean, and fit it on the nozzle. The nozzle cap must be removed and stored in a clean place during operation.

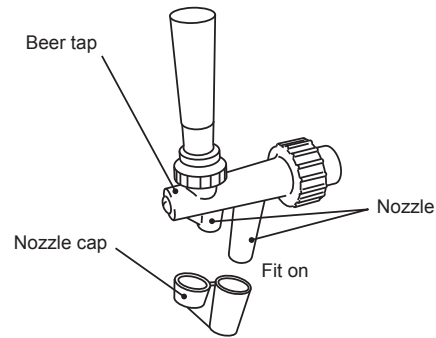

#### IMPORTANT

- To prevent excessive mixture of CO2 gas in draft keg beer, be sure to close the main valve of the CO2 gas cylinder at the end of operation.
- The accessory nozzle cap protects the beer tap nozzle against dust or insects while the dispenser is not used. Always cap the nozzle at the end of operation.
- When the keg coupler on the keg is closed, gas may stay inside the beer circuit. To prevent excessive foaming or improper dispensing actions, lead beer into the beer circuit until gas comes out of the beer tap before starting operation on the following day.

### III. MAINTENANCE

#### IMPORTANT

- After closing time, be sure to carry out the following maintenance procedures.
- Follow the maintenance instructions below whenever considered necessary.
- In cleaning operations, be careful not to lose any parts. The unit will leak water or fail to dispense properly.
- Always use clean hands and cloths to conduct cleaning operations.
- As a sanitizer, use a mixture of warm water (30 - 40°C) and 10 mL of 10% invert soap (benzalkonium chloride). Before using the sanitizer, thoroughly read the instructions provided.
- To prevent damage to the plastic surfaces, do not use thinner, benzene, petroleum, soap powder, polishing powder, alkaline detergent, scrub brush, and especially cleanser for use on fans and cooking ranges. Also, to prevent corrosion, do not use a chlorine bleach (sodium hypochlorite).

## 1. BEER CIRCUIT (DAILY)

### IMPORTANT

Use the cleaning tank specified by the beer company. Follow the operating instructions provided on the cleaning tank.

- 1) Close the beer circuit before flushing.  
Rotary type: Turn the keg coupler handle counterclockwise until it stops.  
Vertical type: Unlock and lift the keg coupler handle all the way up.

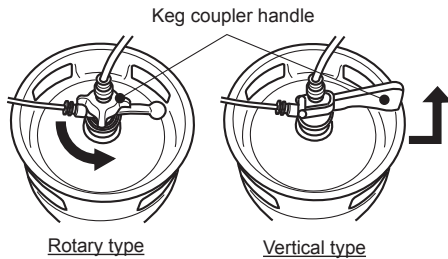

- 2) Turn the regulator adjust dial counterclockwise to "0".

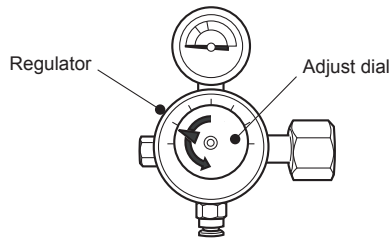

- 3) Shut off the CO2 gas cylinder by turning the main valve clockwise.
- 4) Move the beer tap lever toward you to dispense beer remaining in the circuit.
- 5) When no more beer comes out, move the lever back to its original position.
- 6) Turn the keg coupler counterclockwise, and remove it from the keg.

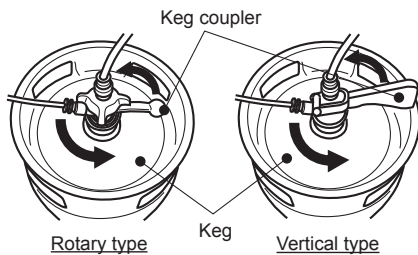

- 7) Wash the cleaning tank thoroughly, and fill it with tap water. A dirty cleaning tank will contaminate the beer circuit.
- 8) Attach the keg coupler on the cleaning tank.

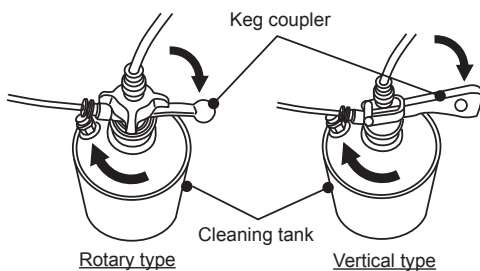

- 9) Check that the beer tap is closed, and open the CO2 gas cylinder by turning the main valve two or three times counterclockwise.

- 10) Turn the regulator adjust dial, and adjust the gas pressure to 0.15 MPa or the allowable range specified on the cleaning tank.

- 11) Open the beer circuit.  
Rotary type: Turn the keg coupler handle clockwise until it stops.  
Vertical type: Push down the keg coupler handle until it locks in place.

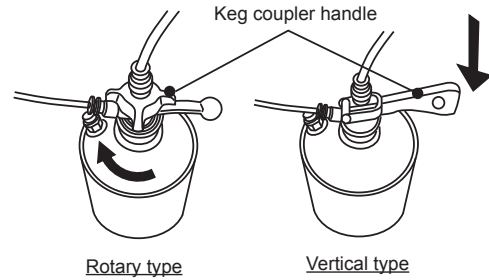

- 12) Check if the cleaning tank is provided with a siphon tube inside.  
If no siphon tube is provided: Turn down the ferrule of the cleaning tank (upside down).  
If siphon tube is provided: Turn up the ferrule of the cleaning tank.

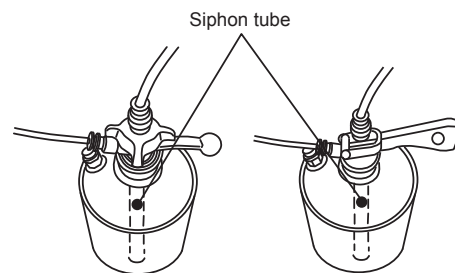

- 13) Prepare a plastic bucket to receive cleaning water. Move the beer tap lever toward you to dispense water. When beer turns into water, move the lever to the back to flush the foam circuit.

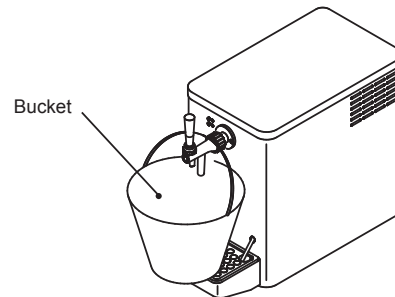

- 14) When no more water comes out, turn the regulator adjust dial counterclockwise to "0". Leave the beer tap open. Shut off the CO2 gas cylinder by turning the main valve clockwise. When the gas stops, move the beer tap lever back to its original position to close the beer tap.

- 15) Close the beer circuit.  
Rotary type: Turn the keg coupler handle counterclockwise until it stops.  
Vertical type: Unlock and lift the keg coupler handle all the way up.

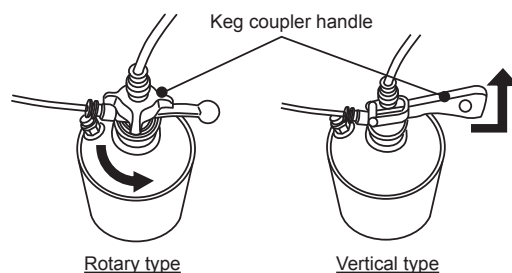

16) Turn the keg coupler counterclockwise, and remove it from the cleaning tank.

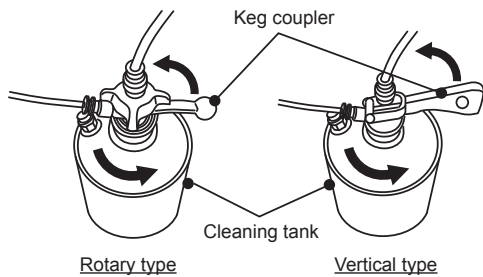

17) Attach the keg coupler on the keg by turning it clockwise until it stops.

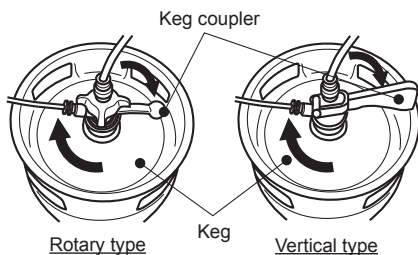

18) Wash the cleaning tank thoroughly, dry it well, and use the cap provided to shut out dust.

19) Wipe moisture from the beer tap nozzle. Wash the nozzle cap clean, and fit it on the nozzle. The nozzle cap must be removed and stored in a clean place during operation.

## 2. BEER TAP (DAILY)

- 1) Loosen the union nut of the beer tap by turning it clockwise, and remove the beer tap.
- 2) Tilt the beer tap lever toward you, and run tap water through the beer tap.
- 3) Refit the beer tap by turning the union nut counterclockwise.

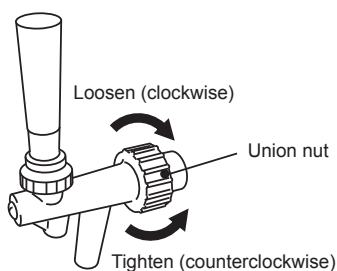

## 3. DRAIN PAN (DAILY)

Wipe the drain pan surfaces by using a cloth containing warm water (30 - 40°C) with invert soap. After 3 minutes, wipe off any remaining soap with a clean cloth containing cold or warm water. Clean the drain pan whenever necessary.

- 1) Remove the drain board, and lift the drain pan to release its mounting holes from the mounting screws. Be careful not to spill water and beer collected in the drain pan.
- 2) Dump water and beer, and wash the drain board and drain pan with tap water.
- 3) Lift the drain pan to hook the mounting holes on the mounting screws, and set the drain board on the drain pan.
- 4) Check that the overflow hose goes through the hole in the drain board and can drain water into the drain pan.

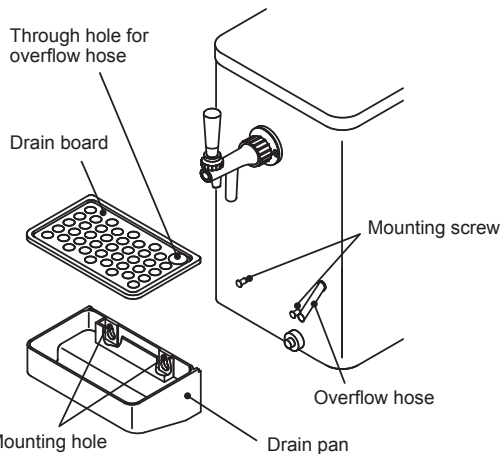

## 4. CLEANING BEER CIRCUIT WITH SPONGE (WEEKLY)

### IMPORTANT

1. Store the used cleaning sponge for later use.
2. Use the cleaning tank specified by the beer company. Follow the operating instructions provided on the cleaning tank.
3. Use one of the cleaning sponges provided. To prevent clogging, do not use more than one sponge or any sponge other than those provided.

- 1) Close the beer circuit before flushing.  
Rotary type: Turn the keg coupler handle counterclockwise.  
Vertical type: Unlock and lift the keg coupler handle all the way up.

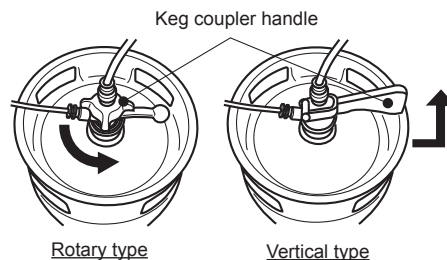

- 2) Turn the regulator adjust dial counterclockwise to "0".

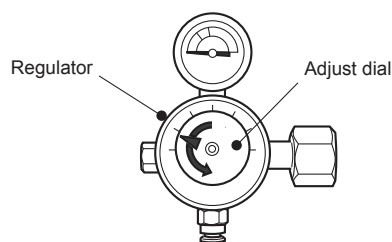

- 3) Shut off the CO2 gas cylinder by turning the main valve clockwise.
- 4) Move the beer tap lever toward you to dispense beer remaining in the circuit.
- 5) When no more beer comes out, move the lever back to its original position.
- 6) Loosen the union nut of the beer tap by turning it clockwise, and remove the beer tap.
- 7) Loosen the cap nut of the beer tap, and disassemble the beer tap. Fit the valve shaft in the opposite direction as shown below, and tighten the cap nut. (This is to prevent the cleaning sponge from clogging the beer tap.)



[Normal Operation]

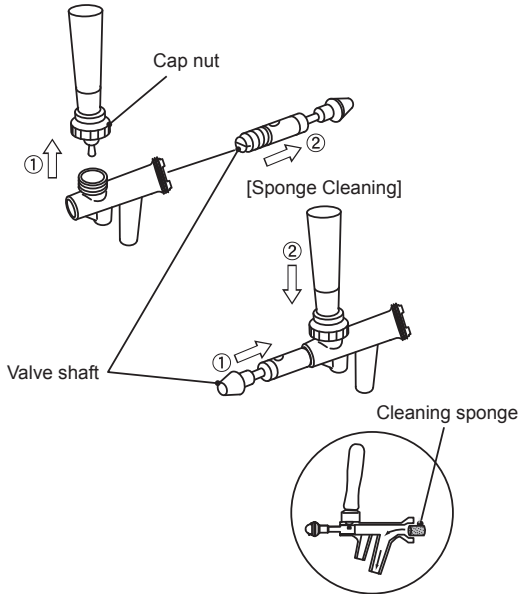

8) Attach the beer tap on the unit by tightening the union nut.

9) Prepare a plastic bucket under the beer tap to receive drain water.

10) Wash the cleaning tank thoroughly, and fill it with tap water.

11) Remove the quick beer hose joint from the keg coupler, put the cleaning sponge into the joint, and refit it on the keg coupler.



12) Attach the keg coupler on the cleaning tank.

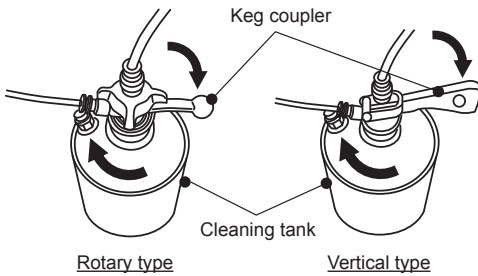

13) Open the CO2 gas cylinder by turning the main valve two or three times counterclockwise.

14) Turn the regulator adjust dial, and adjust the gas pressure to 0.15 MPa or the allowable range specified on the cleaning tank.

15) The cleaning sponge will come out with water.

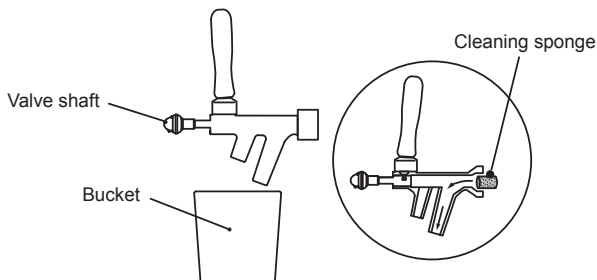

16) When the cleaning sponge and water have come out, turn the regulator adjust dial counterclockwise to "0". Shut off the main valve of the CO2 gas cylinder. Wait until gas stops flowing out of the beer tap.

17) Close the beer circuit.

Rotary type: Turn the keg coupler handle counterclockwise.  
Vertical type: Unlock and lift the keg coupler handle all the way up.

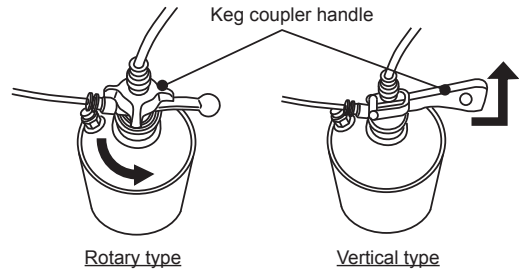

18) Turn the keg coupler counterclockwise, and remove it from the cleaning tank.

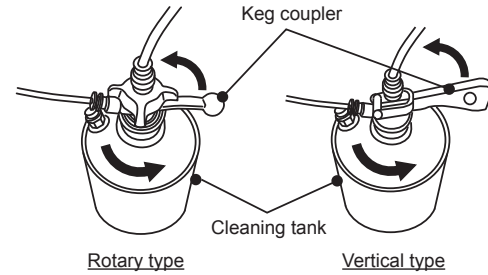

19) Recover the cleaning sponge from the bucket.

20) Repeat the above steps 10) to 16) until clear water comes out of the beer tap.

21) Remove the beer tap, set the valve shaft in its normal position, and refit the beer tap on the unit.

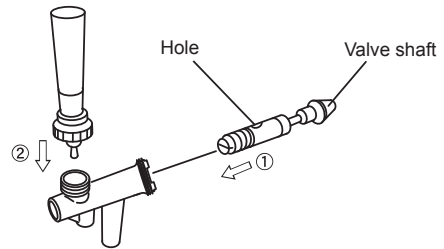

22) Attach the keg coupler on the keg.

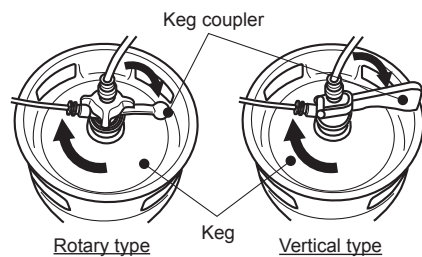

23) Wash the cleaning sponge thoroughly with tap water. Drain and store it for later use.

## 5. DISASSEMBLY AND CLEANING OF BEER TAP (WEEKLY)

1) Close the beer circuit before flushing.

Rotary type: Turn the keg coupler handle counterclockwise.  
Vertical type: Unlock and lift the keg coupler handle all the way up.

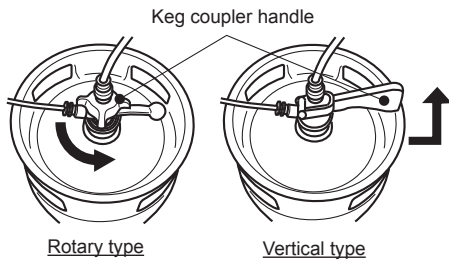

- 2) Turn the regulator adjust dial counterclockwise to "0".
- 3) Move the beer tap lever toward you to dispense beer remaining in the circuit. Loosen the union nut of the beer tap by turning it clockwise, and remove the beer tap.
- 4) Loosen the cap nut of the beer tap, and remove the lever.

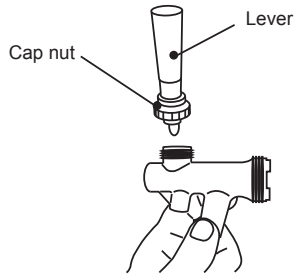

- 5) Remove the valve shaft from the beer tap.

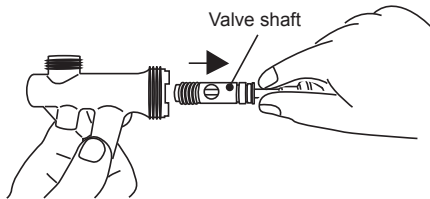

- 6) Clean the beer tap and valve shaft by using a neutral dishwashing detergent and the accessory cleaning brush.
- 7) Use the accessory brush (S) to clean the two small holes in the beer tap.

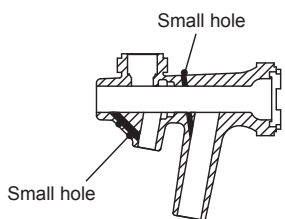
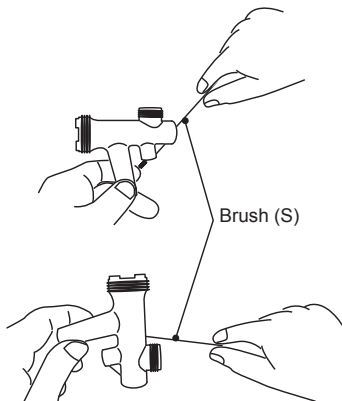

Beer tap cross section

- 8) Rinse the beer tap thoroughly with clean water.

- 9) Assemble the beer tap properly by positioning the hole in the valve shaft (larger hole facing up).

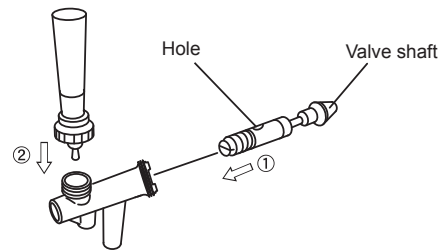

## 6. KEG COUPLER (WEEKLY)

Clean the keg coupler in accordance with the beer company's instruction manual.

## 7. EXTERIOR (WEEKLY)

The stainless steel exterior also needs cleaning to prevent possible corrosion. Wipe with a soft cloth. Use a soft damp cloth containing a neutral dishwashing detergent to wipe off dirt buildup, and remove any remaining detergent. Clean the exterior whenever necessary.

## 8. AIR FILTER (BIWEEKLY)

- 1) Remove the drain pan.
- 2) Pull the air filter slightly toward you. Push it down, and pull it out.
- 3) Wash the air filter with cold water or warm water containing a neutral dishwashing detergent. Be careful not to break the net. After using a detergent, rinse the air filter thoroughly. Dry it in the shade.
- 4) Fit the air filter into the filter guide at the bottom, and slide it to the back.
- 5) Refit the drain pan.

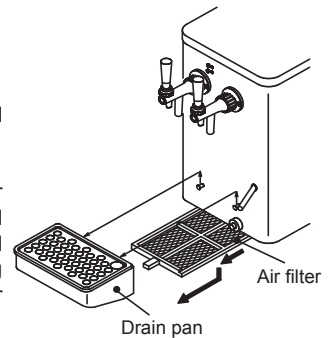

### IMPORTANT

1. When the air filter is clogged with dirt and dust, the unit cannot operate properly.
2. Do not operate the unit with the air filter removed. The condenser will clog easily.
3. To prevent deformation, do not wash the air filter with hot water above 40°C.
4. Do not hit or drop the drain pan and air filter while cleaning them.

## IV. INSPECTION

### 1. GAS HOSE AND BEER HOSE (MONTHLY)

Check the gas and beer hoses for damage, deformation, and water leak marks (stains). If any problem is found, contact an authorized Hoshizaki service company.

### 2. ATTACHMENT PLUG AND POWER CORD (ANNUALLY/ BIANNUALLY)

#### CAUTION

1. Check periodically that the attachment plug blades and their vicinity are free of dust and that the attachment plug is securely plugged into the receptacle. Dusty blades or loose connection may cause electric shock or fire.

2. Do not damage the power cord. It should not be additionally processed, jerked, bundled, weighed down or caught in. It could cause electric shock or fire.
3. The unit must have a separate power supply. Branching off the power cord, using an extension cord, or sharing a single power supply with other appliances may result in electric shock, heat generation or fire.

Check that:

- \* The attachment plug blades and their vicinity and the receptacle are free of dust. Clean them if necessary.
- \* The attachment plug and power cord are not damaged, weighed down or caught in.
- \* The attachment plug is plugged into a separate receptacle.

### 3. COOLING WATER (BIANNUALLY)

- 1) Unplug the unit.
- 2) Remove the top cover and inner cover.
- 3) Check that the cooling water level is about 2 cm below the top of the water tank (DBF-25SB-AU) or up to the standard water level marked on the tank (DBF-43SB-AU). If it is insufficient, refill the water tank with tap water. Refresh the cooling water twice a year.

To refresh the cooling water:

- 4) Remove the drain pan.
- 5) Prepare a large container to receive drain water [about 6 L (DBF-25SB-AU) or 8 L (DBF-43SB-AU) in ice storage]. Remove the drain plug, and drain the water tank. After the cooling water has drained out, refit the drain plug.
- 6) Refill the water tank according to "I. 5. [a] COOLING WATER SUPPLY".
- 7) Refit the top cover and inner cover.
- 8) Plug in the unit.

#### IMPORTANT

Dust, bacteria, and moisture in the air may cause contamination or reduction in conductivity of the cooling water. To prevent clogging of the overflow hose or inadequate ice storage, refresh the cooling water twice a year.

If the cooling water conductivity reduces and no ice is produced in the water tank, fill 1/3 (2 g) of the nozzle cap with baking soda. Do not use an excessive amount of baking soda or any other substances such as salt, vinegar, and juice. They will corrode the stainless steel and copper tubes and cause failure.

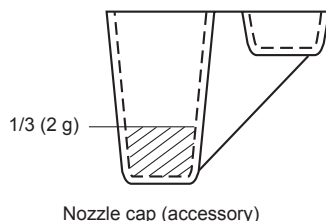

### V. LONG STORAGE, RELOCATION, DISPOSAL, TRANSFER

- \* When shutting down the unit for more than a week, carry out the following maintenance procedures to clean and drain the beer circuit and to keep the unit clean:

- III. 4. CLEANING BEER CIRCUIT WITH SPONGE
5. DISASSEMBLY AND CLEANING OF BEER TAP
6. KEG COUPLER
7. EXTERIOR
8. AIR FILTER

Drain the water tank according to "IV. 4. COOLING WATER". It takes a few days to melt ice left in the water tank. After melting all the ice, drain the water tank again, and dry the tank interior.

- \* In case of relocation or disposal of the product, contact an authorized Hoshizaki service company.

- \* When selling or transferring this product, tape this instruction manual to the exterior to provide the new owner with information on safe and proper use of the product.