



Our new **S4E V3 carbonated icebank Superchiller** now delivers greater performance, improved serviceability, reliability and reduced power consumption.

Features

- Low installation, operating and maintenance costs
- Large icebank provides extensive reserve capacity for heavy peak demand periods
- Designed for ease of service
- External removable condenser filters
- Vertically in-line pump motors
- Pre-coloured soda and water supply and return tubes to match soft drink python colours for ease of installation and service
- Serial plaque with QR code link to on line manual
- Operates on environmentally responsible R134a refrigerant
- Magnetic pump – unique magnetic drive soda pump for significantly improved reliability
- Australian designed and manufactured to operate in most demanding conditions
- Diagnostic LED's and audible alarm to assist technician
- Pump and motor isolation switch.

Options

- Wheels or adjustable legs
- Syrup coils

Certified by these agencies:



CUSTOMER SERVICE

Should you require more information about our products, please do not hesitate to contact our customer service team at lancerservice@lancerworldwide.com



WARRANTY

For warranty specifics by product, contact your Lancer Sales Representative. Equipment design and/or specifications are subject to change without notice.

For more Information visit lancerbeverage.com or call +61 8 8268 1388

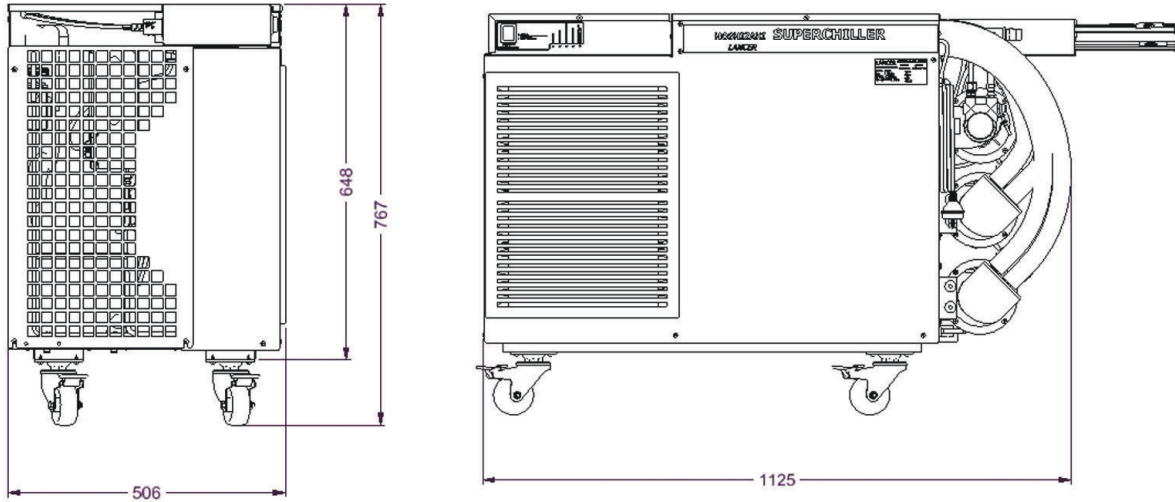

Product Range

Part #

01000344
01000345

Description

Superchiller S4E V3 3 pump
Superchiller S4E V3 2 pump

Drink Capacity

275 x 355ml (12oz) drinks below 4.4°C at 4 drinks per minute with 40°C ambient, syrup inlet temperature and 32°C water inlet temperature.

Dimensions

Width 1050mm Depth: 505mm Height: 655mm

Weight

Empty: 103kg Operational: 175kg Shipping: 110kg

AC Supply Voltage

240V/50Hz, 10 Amps

Capacity

1765 Watts

Icebank Weight

Nominal 30kg

Ambient Temperature

2 C – 40 C

Refrigerant

R134a

For more Information visit lancerbeverage.com or call +61 8 8268 1388