



772 MULTI-FLAVOR

PRODUCT SPECIFICATIONS



Capacity

| Electric Frequency | 60 Hz | | | 50 Hz | | |
|--------------------|--|--------------------------------------|--|--------------------------------------|---------------|--|
| | Dispenser Type | Barrel Volume | Continuous Draw - Single Barrel [§] | Dispenser Type | Barrel Volume | Continuous Draw - Single Barrel [§] |
| | Air-Cooled | 176 oz | - | Air-Cooled | 5,205 mL | - |
| | Remote | N/A | N/A | Remote | N/A | N/A |
| | Water-Cooled | N/A | N/A | Water-Cooled | N/A | N/A |
| | Continuous Draw - Alternating Barrels [§] | 4,500 oz/hr | 115,337 mL/hr | | | |
| | Recovery Time [§] | 4 mins | 4 mins | | | |
| | Refrigeration | 15,000 BTU/hr (15,826 kJ/hr), R-404A | | 19,000 BTU/hr (20,046 kJ/hr), R-404A | | |

[§] Testing completed at 75°F (24°C).

Electrical Requirements

| Electric Frequency | 60 Hz | | 50 Hz | |
|--------------------|----------------------|---|-----------------------------|---|
| | Voltage | 215 - 245 VAC ^Δ , Single Phase | | 215 - 245 VAC ^Δ , Single Phase |
| Current/Power | 20 Amps | | 3,000 W | |
| Receptacle | NEMA #L6-20R, 3 Wire | | Varies depending on market. | |
| Beater Motor | (2) 1/6 HP, 0.85 A | | (2) 1/6 HP, 0.81 A | |
| Fan Motor | (1) 1/6 HP, 0.83 A | | (1) 1/6 HP, 0.43 A | |

^Δ Buck-boost transformer required for operation outside this range.



Frozen Beverage Dispensers
EVERYONE LOVES FROZEN™

772 MULTI-FLAVOR

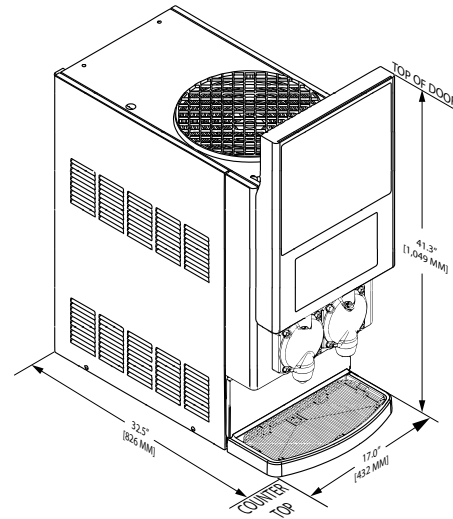
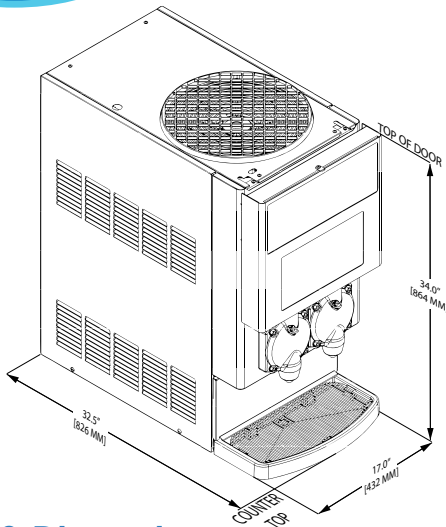

Weights & Dimensions

| Measuring System | Imperial | | | Metric | | |
|----------------------------|----------------------|--------|-----------------------|---------------------|--------|-----------------|
| | Short Door | | Tall Door | Short Door | | Tall Door |
| Door Model | Short Door | | Tall Door | Short Door | | Tall Door |
| Height | 34.0 in | | 41.3 in | 864 mm | | 1,049 mm |
| Width | 17.0 in | | | 432 mm | | |
| Depth | 32.5 in | | | 826 mm | | |
| Back/Side Clearance (Min.) | 3 in | | | 76 mm | | |
| Top Clearance (Min.) | 12 - 36 in* | | | 304 - 914 mm* | | |
| Duratrans | 6 1/2 in x 15 3/4 in | | 14 1/8 in x 15 3/4 in | 165 mm x 400 mm | | 359 mm x 400 mm |
| Flavor Card | N/A | | | N/A | | |
| Screen Size | 13.3 in Touch Screen | | | 338 mm Touch Screen | | |
| Dispenser Type | Air-Cooled | Remote | Water-Cooled | Air-Cooled | Remote | Water-Cooled |
| Empty Weight | 310 lbs | | N/A | 141 kg | | N/A |
| Operating Weight | 333 lbs | | N/A | 151 kg | | N/A |

* 12 in (304 mm) with side or back open-air conditions, 36 in (914 mm) in equipment alcove.

Water, CO₂ and Syrup Requirements

| Measuring System | Imperial | | Metric | |
|--|---|---|--------------------------|--|
| | Water System Input | 3/8" Supply Line, 30 PSIG Flowing (minimum) | | 3/8" Supply Line, 207 kPag Flowing (minimum) |
| CO ₂ System Input | 70 - 72 PSIG (maximum) | | 483 - 496 kPag (maximum) | |
| Condenser Water Inlet Flow Rate ^o | N/A | | N/A | |
| Condenser Water Inlet Temperature ^o | N/A | | N/A | |
| Syrup | Input: 70 - 72 PSIG (482 - 496 kPag) | | | |
| | Bag-In-Box (BIB) Connections, (2) Base Syrups and (8) Flavor Injection Syrups | | | |

^o For water-cooled dispensers.