

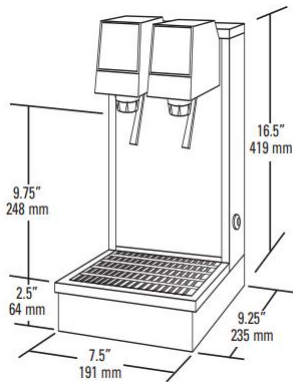

The Tower 300 guarantees consistent drink quality through its use of premium materials and proven technology, ensuring customer satisfaction and a reliable beverage experience.

- Available in 1, 2, 5, or 6 valves
- Island base dispensing towers
- Stainless steel construction
- Designed for easy installation
- All valves can be serviced independently
- Power supply included

Configuration

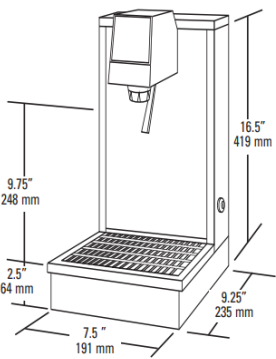

Dimensions	Width: 191mm, Depth: 235mm, Height: 419mm
Weight	Shipping: 7kg
Electrical	24VAC/60Hz
Valves	LEV® and other valves available upon request

Dimensions	Width: 470mm, Depth: 267mm, Height: 406mm
Weight	Shipping: 17kg
Electrical	24VAC/60Hz
Valves	LEV® and other valves available upon request

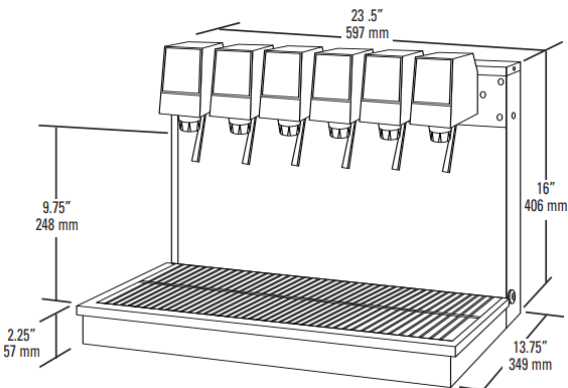
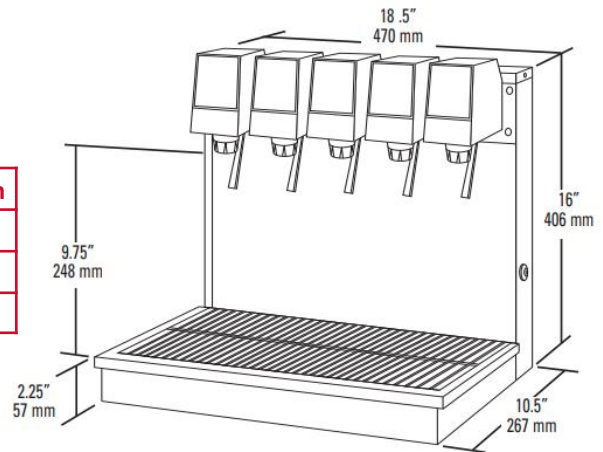

Dimensions	Width: 597mm, Depth: 349mm, Height: 406mm
Weight	Shipping: 19.05kg
Electrical	24VAC/60Hz
Valves	LEV® and other valves available upon request

Warranty