



Lancer's **CED 600** is the Next Generation Counter Electric Dispenser - reliability, together with a clean, green refrigerant. A great option for carbonated as well as alternative beverages.

### Features

- In compliance with green initiatives, the **CED 600** uses R290 refrigerant making fountain even greener
- Consistent cold carbonation
- Fully louvered top provides air circulation for more efficient operation
- No need for countertop cutout
- 3-way back block
- Stainless steel construction exterior and interior
- Improved insulation is CFC free, 0 GWP (Global Warming Potential) structural foam
- LEV® Valves standard, other valves available upon request
- Key Lock Switch
- Lancer™ Electronic Ice Bank Control

### Accessories and Options

Shrouded Merchandiser  
R134a Refrigerant

Certified by these agencies:



#### CUSTOMER SERVICE

Should you require more information about our products, please do not hesitate to contact our customer service team at [custserv@lancerworldwide.com](mailto:custserv@lancerworldwide.com).



#### WARRANTY

For warranty specifics by product, contact your Lancer™ Sales Representative. Equipment design and/or specifications are subject to change without notice.

CED 600 with optional shrouded merchandiser

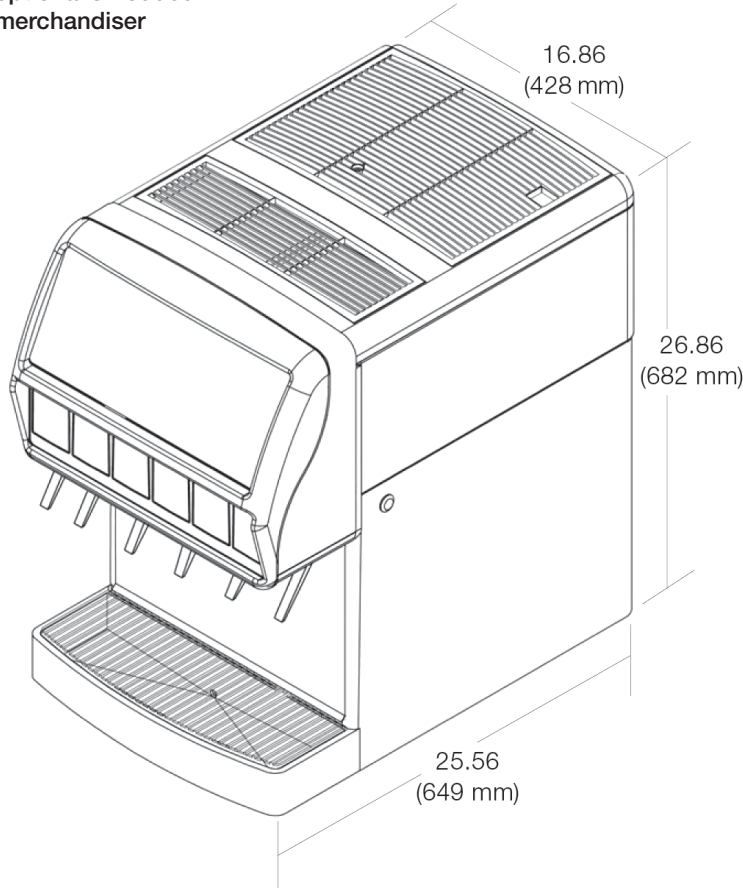

## Distinctive Design

- Flex Manifold Configuration



### Dimensions

26.86" H x 16.86" W x 25.56" D  
(682 mm H x 428 mm W x 649 mm D)

### Weight

Empty: 160 lbs (73 kg)  
Operating: 240 lbs (109 kg)  
Shipping: 180 lbs (82 kg)

### Ice Bank Weight

20 lbs (9 kg)

### Electrical

115V/60Hz, 8 Amps  
230V/50Hz, 4 Amps

### Compressor

407W (230V/50Hz)  
285W (115V/60Hz)

### Fittings

Carbonated Water Inlet: 3/8"(9.5 mm) male flare  
Plain Water inlet: 3/8"(9.5 mm) male barb  
Syrup inlets: 1/4"(6.35 mm) male barb

For more information visit [lancerworldwide.com](http://lancerworldwide.com) or call 1-800-729-1500

6655 Lancer Boulevard • San Antonio, TX 78219 • 210-310-7000 • Fax: 210-310-7250 • © 2021 Lancer® Worldwide • CED 600 12/21

"Lancer" and "Lancer Worldwide" are trademarks of Lancer Corp. © 2021 by Lancer®, all rights reserved.