

6795-C

FROZEN BEVERAGE FREEZER

SPACEMAN AUSTRALIA

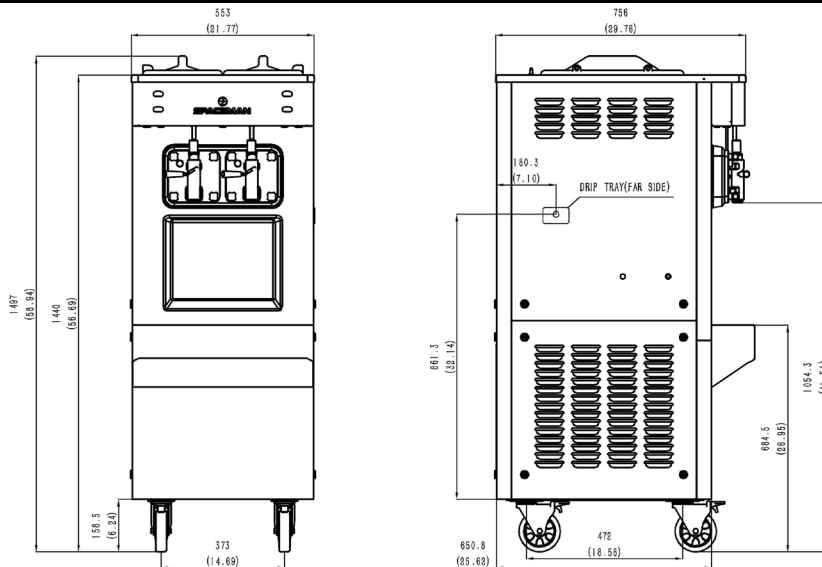

SPECIFICATIONS

Flavors	2
Freezing Cylinders	2 x 6.9L / 7.3qt
Mix Hoppers	2 x 12L / 12.7qt
Output Capacity (250ml)	480 serves/hr
Clearance Requirements	152mm/6" on right

Weight	Kg/lb
Net	250 / 551
Shipping Cylinders	270 / 592
Volume	0.98 CBM / 34.75 CBF

Dimensions	Net (mm/in)	Shipping (mm/in)
Width	535 / 21.8	710 / 28.0
Depth	651 / 25.6	830 / 32.7
Height	1497 / 58.9	1670 / 65.7

Electrical	Fuse	Amps	Power(kW)
220-240/50/1	30	22	4.6
208-230/60/1	30	24	5.0

FEATURES

Control System	Two, Mechanical
Refrigerated Hopper	✓
Hopper Agitator	✓
Standby Mode	✓
Auto Closing Dispensing Valve	✓
Low Mix Indicator Light	✓
Low Mix Indicator Alarm	✓
Standby Indicator Light	✓
High Pressure Protection	✓
Thermal Overload Protection	✓

AVAILABLE OPTIONS

Top Air Discharge Chute	✓
Spinner	✓
Light Box	✓

• Above specifications are subject to change without notice

